



# BALOO'S BUGLE



Volume 15, Number 6

"Make no small plans. They have no magic to stir men's blood and probably will not themselves be realized." D. Burnham

January 2009 Cub Scout Roundtable

February 2009 Cub Scout Theme

## AMERICAN ABC's

Tiger Cub Activities

Webelos Scholar and Engineer

### FOCUS

*Cub Scout Roundtable Leaders' Guide*

Let's tour the united States by the letters: Austin, Baton Rouge and Cambridge to Xenia, York, and Zion. This month, Cub Scouts will explore scenic and historic landmarks in this wonderful country. **What a great theme for your Blue and Gold Banquet!!** A den or pack may choose a city or state, and the boys can learn all about it. Or you might decide on a theme such as national parks, zoos or museums. The boys can use their choice in their decorations, skits, and songs for the banquet.

### CORE VALUES

*Cub Scout Roundtable Leaders' Guide*

**Some of the purposes of Cub Scouting developed through this month's theme are:**

- ✓ **Fun and Adventure.** Boys will enjoy the trip through history and across the nation as they discover what America has to offer.
- ✓ **Preparation for Boy Scouts,** Boys will learn to honor America as all boys should.
- ✓ **Family Understanding,** Families will be strengthened as family members share the experiences of places they have been.

**The core value highlighted this month is:**

- ✓ **Citizenship,** Through learning about people and places in America the boys will come to understand what being a citizen entails and develop pride in America.

**Can you think of others???** Hint – look in your **Cub Scout Program Helps.** It lists different ones!! All the items on both lists are applicable!! You could probably list all twelve if you thought about it!!

### COMMISSIONER'S CORNER

Look at the top - this is the halfway mark of the 2008-2009 Scouting year. And I am still running late. I spent the Saturday after Christmas working on Baloo (my daughter and wife were both at work) and much of this week, too.

Our Pow Wow is in a few weeks and then I have to get serious about Webelos Resident and Philmont. Busy!

Pow Wow Books have been arriving at my door or E-mail regularly. Thank you all so much. I have Sam Houston

Area, Great Salt Lake, Oregon Trail, Catalina, National Capital Area Council, Buckeye, LaSalle County, Seattle Area, and Santa Clara County. I will be E-mailing those who sent me books with how I plan to get you my swaps. Thank you so much.

***BUT if you have one I did not name - do not hesitate to send it to me - Write me for directions, please***

**Months with similar themes to American ABC's**  
*Dave D. in Illinois*

Month Name	Year	Theme
<b>American Geography</b>		
July	1955	Discovering America
April	1960	The Great Lakes
March	1963	Around the U.S.A.
April	1967	Mountains of America
July	1971	Travel around U.S.A.
February	1976	Horizons USA
October	1977	Discover America
November	1978	High Country USA
November	1981	Discover America
July	1991	High Country, USA
August	1996	High Country, USA
July	2001	American ABC's
<b>American Heritage</b>		
February	1962	Parade of Presidents
October	1972	Discovery of America
February	1973	Famous Americans
June	1973	Flags of America
October	1976	Outstanding Presidents
June	1981	Flags of America
November	1985	Parade of the Presidents
September	1987	Flags of America
November	1989	Parade of the Presidents

**Eagle Info**

Mike Rowe from dirty Jobs is an Eagle Scout and he has a pair of great letters on his blog at [http://discovery.blogs.com/mike\\_rowe\\_answers/](http://discovery.blogs.com/mike_rowe_answers/). The letters are to Boy Scouts - one to a boy getting close to Eagle and the other a congratulatory letter to a new Eagle Scout. A few years away for most Cub Leaders but great reading.



National makes a patch for every Cub Scout Monthly theme.

This is the one for this theme. Check them out at [www.scoutstuff.org](http://www.scoutstuff.org) go to patches and look for 2009 Cub Scout Monthly Theme Emblems.

*(Actually, the file for 2009 patches has not yet been created!! Being a volunteer I do not get complete answers to my questions to Supply Division about these patches. They apparently don't feel any need to post them.)*

## THOUGHTFUL ITEMS FOR SCOUTERS

*Thanks to Scouter Jim from Bountiful, Utah, who prepares this section of Baloo for us each month. You can reach him at [bobwhitejonz@juno.com](mailto:bobwhitejonz@juno.com) or through the link to write*

*Baloo on [www.ussscouts.org](http://www.ussscouts.org). CD*

### **Roundtable Prayer**

*CS Roundtable Planning Guide*

O Lord, we thank you for all the blessings you have bestowed upon us and this nation. Help us do our duty to you and our county. Help us do our best to guide the youth so they can grow up to be good men for this great nation.

**AMEN**

*Sam Houston Area Council*

We are thankful to live in this country where we have the freedom to worship as we wish. May we always remember that all of us are Your children. **Amen.**

### **American ABC's**

*Scouter Jim, Bountiful UT*

One early morning, while waiting for the bus, after not working for a while, I realized I had missed road noise. As Scout Leaders, we are all about nature and the outdoors. When we think about Scouting, most think about quiet and solitude or the wilderness, the sound of a mountain stream, the call of wild birds. We don't often think about the places we live, in the cities and towns of America. Roads as we know them are an invention of the last century. Many if not all of us have heard the song about Route 66, the road that crossed the country from Chicago across the country to Los Angeles. There is also the Lincoln Highway, the Dixie Highway and many other named roads. There are Scenic Byways all across the country, place to visit, with a history to tell

The street where I catch the bus every workday morning has a number, but just down the street it changes to a named

road. Most people don't remember why they call it "Orchard Drive." On the far south end many years ago there were orchards where people would come from miles around to purchase fruit. On the far north end, there used to be a church owned farm with fruit trees and a small dairy, all of which, for the most part, were operated by volunteers with all the production of the orchard and dairy being processed and given to needy families. I remember being taken there by my father with my older brothers to do volunteer work. I did what little work a young lad could do, picking up branches and hauling them out of the fields after other had pruned trees. The orchards and the farm are now gone, replaced by urban sprawl and a subdivision.

There is a another road in my county that runs east to west named Antelope Drive. Should you drive the road west from I-15 to the edge of the Great Salt Lake, you would come to an entrance booth to the causeway to Antelope Island State Park. After paying a Park entrance fee, you could drive the road across the Great Salt Lake to a wonderful State Park with clean sandy beaches and its own herd of Buffalo roaming the Island.

I am not trying to brag about where I live. I am merely trying to raise the competitive spirit in the reader to say, *Oh yea, well you ought to see what we have around here. There is this great place right down the road. We have some wonderful history right here in our city park.* That is the reaction that this month is all about. Teaching boys about where they live and the reasons that things are the way they are. Where did your town get its name. I bet there is a story to tell there. Beyond the boundaries of your community, to the wonders of you state, what stories are there to tell? What places are there to visit near where you live? Beyond the boundaries of your state, what places of history and beauty are there in you region? Let us teach our Cub Scouts about the America, and the States and the towns where they live.

Web Link: <http://www.byways.org> America's Scenic Byways

### **Bless The Cub Scouts**

*Catalina Council*

(Tune: Bless This House)

Bless the Cub Scouts, Lord, we pray.  
 Keep us healthy all the day.  
 Let us know our Cub Scout sign,  
 Have it always on our mind.  
 If you do, we promise then,  
 We'll become good future men.  
 Hear our prayers at night and day,  
 Guide us, O Lord along your way.  
 Bless the Cub Scouts, Lord, we pray,  
 Keep us healthy all the day.

### Quotations

Quotations contain the wisdom of the ages, and are a great source of inspiration for Cubmaster's minutes, material for an advancement ceremony or an insightful addition to a Pack Meeting program cover

The World is a book, and those who do not travel read only a page. [St. Augustine](#)

Wandering re-establishes the original harmony which once existed between man and the universe. [Anatole France](#)

No one realizes how beautiful it is to travel until he comes home and rests his head on his old, familiar pillow.

[Lin Yutang](#)

Travel and change of place impart new vigor to the mind. [Seneca](#)

The traveler was active; he went strenuously in search of people, of adventure, of experience. The tourist is passive; he expects interesting things to happen to him. He goes "sight-seeing." [Daniel J. Boorstin](#)

It is not down in any map; true places never are. [Herman Melville](#)

The whole object of travel is not to set foot on foreign land; it is at last to set foot on one's own country as a foreign land. [G.K. Chesterton](#)

To get away from one's working environment is, in a sense, to get away from one's self; and this is often the chief advantage of travel and change. [Charles Horton Cooley](#)

And that's the wonderful thing about family travel: it provides you with experiences that will remain locked forever in the scar tissue of your mind. [Dave Barry](#)

I soon realized that no journey carries one far unless, as it extends into the world around us, it goes an equal distance into the world within. [Lillian Smith](#)

I have found out that there ain't no surer way to find out whether you like people or hate them than to travel with them. [Mark Twain](#)

Travel is fatal to prejudice, bigotry, and narrow-mindedness, and many of our people need it sorely on these accounts. Broad, wholesome, charitable views of men and things cannot be acquired by vegetating in one little corner of the earth all one's lifetime. [Mark Twain](#)

We wander for distraction, but we travel for fulfillment. [Hilaire Belloc](#)

Like all great travelers, I have seen more than I remember, and remember more than I have seen. [Benjamin Disraeli](#)

*Sam Houston Area Council*

America's future walks through the doors of our schools each day. [Mary Jean Le Tendre](#)

A journey of a thousand miles must begin with a single step. [Lao Tzu](#)

One's destination is never a place, but a new way of seeing things. [Henry Miller](#)

Two of the greatest gifts we can give our children are roots and wings. [Hodding Carter](#)

There are no seven wonders of the world in the eyes of a child. There are seven million. [Walt Streightiff](#)

It was kind of solemn, drifting down the big, still river, laying on our backs, looking up at stars, and we didn't even feel like talking aloud." [Mark Twain \(from Huckleberry Finn\)](#)

Boy, n.: a noise with dirt on it. [Not Your Average Dictionary](#)

## TRAINING TIP

### What Do Ceremonies Do??

[Bill Smith](#), the Roundtable Guy

### What do Ceremonies do?

#### Celebrate the Occasion

Our ceremonies often observe the importance of an event. We need to stop what we are doing and reflect on the moment. Ask: Why is this time important? What really happened? What does it mean to us?

The range of events we celebrate this way is expansive from simple, personal to profound and universal. A ceremony can mark the opening of a den meeting: The fun is about to start! A Blue and Gold banquet acclaims: Scouting is one hundred years old! Special times like Memorial Day and the Fourth of July extol our heritage and history.

We stop doing our usual routines and honor something of value in our lives. We gather together, we hold a ceremony for the occasion. These moments are special and contribute to the meaning and spirit of our lives.

Ritual replaces our normal-day discourse and activities in these ceremonies. Reciting the *Cub Scout Promise* at a den meeting, singing the *Star Spangled Banner* or *Take Me Out To The Ball Game* at MLB games and throwing the bouquet at a wedding are just some of the rituals we use at these special times. They are important and we should do our best to punctuate our ceremonies with rituals that instruct and inspire.

Each pack and each den will have its own set of rituals that make Cub Scouting and its character connections part of a boy's life. Families too have their own rituals, like those described by Michael Gurian in [Scouting Magazine](#).

### Protect your family rituals like they are gold.

### We Recognize the Person

Our ceremonies acknowledge the importance and value of the individual. Ceremonies are formal opportunities to present awards and honors to Cub Scouts who have worked hard for them. Ceremonies are your chance to praise a boy's work in front of his parents, his friends and even in front of strangers, thus making him the focus of attention for a short, but significant period of time. At the same time ceremonies encourage other Cub Scouts to complete their own programs. The key to any and all Cub Scout ceremonies is the boy.

### How often do parents get to thank and praise their sons in public?

We respect the boy's accomplishments when we present him with rank badges and arrow points. We use ceremonies to show how much we appreciate the fact that he is here with us. We call out his name and repeat it more than once during those few seconds he is in the spotlight. It's the boy we applaud, not the badge.

I am a big fan of dramatic lighting at ceremonies. A Scout trainer once pointed out to me that a single candle in a darkened room is effective because there is nothing else to look at except what the candle illuminates. So when you use candle-lit ceremonies, make sure that the boy faces the audience and the light shines on his face so that everyone in the room can see just him. Don't block the view. This is his moment!

### **We Commemorate the Importance**

Our ceremonies fix the events in our memory. One of the most important aftermaths of a good ceremony is that we remember it. Years later we can recall what was done, what was said and what effect it all had on our lives. Make your ceremonies occasions to remember and treasure.

Surprising, dramatic effects help to make the ceremony memorable. Vary your methods enough each time so that you catch and hold everyone's attention. Change the sight, sound, and atmosphere to catch your audience a bit off-guard. Both participants and the audience will pay closer attention and remember it longer.

The glow of a campfire or other lighting effects can emphasize the action and effects. Recorded sounds of nature or music add to the experience. The smell of pine boughs or wood smoke evokes strong feelings that many hold dear. Your ceremonies should trigger as many senses and communication channels as possible.

Symbols representing Scouting's ideals are essential to make a ceremony meaningful and to perpetuate the experience. Typical are candle (fake or real) representing the spirit of Scouting and three lights standing for the critical Character Connection areas. Neckerchiefs are invitations to the outdoors and adventure. Use lots of symbols to emphasize your message.

Participation intensifies the experience. Remember that boys are happiest when they are doing things so give them something to do in their ceremonies. Using simple props like the *Ceremony Ladder* or the *Pack Advancement Board* {How-To Book, pp1-2, 1-3} where the boy moves his token to the next rank work well.

Packs that tie their ceremonies to the monthly themes have lots of opportunities to surprise their members with unique and unforgettable times. Getting your badge as pirate booty or an astronaut discovering a new planet is a lot more vivid and easier to relive than just having it handed to you. Activity badges have more impact when your ceremony ties the pins to Geology, Travel etc. You may recall those spectacular [Run-On awards of Kriste Ryan](#) we related in the October 2007 Bugle. It's worth the time to go back and read it again.

The Tiger Cub Scout who pops a balloon to discover that it contains his Bobcat Badge will remember that night. So will the graduating Webelos who is greeted at the far end of the bridge by Boy Scouts holding a flaming troop neckerchief.



Career Arrow -1967

There was a great Scouting Ceremony two years ago that lasted several months and that involved thousands of people.

### **Scout and Guide Spirit Flame**

**February 22, 2007 marked the 150th anniversary of the birth of Scouting's founder: Robert Baden-Powell. On that day, several thousand Scouts and Guides from around the world assembled at his grave site in [Nyeri, Kenya](#) where a torch was lit.**

**The flame was carried by Scouts and Guides through Ethiopia, Sudan, Egypt, Greece, Italy, France, Belgium and finally the UK to arrive on [Brownsea Island, UK](#) on the eve of Scouting's Sunrise. After the Sunrise celebrations on 1 August 2007, the flame continued onwards to the 21st World Scout Jamboree.**

**The flame that traveled from Africa was used to light a campfire that burned through the night, marking the passing of the first 100 years of the Scout movement.**

I would imagine that most of those who walked from BP's home to his grave site, or lit the Spirit Flame, or carried the torch or who tended the campfire were moved by the experience and will remember it for years to come.

### **What are YOU going to do now?**

***Go get 'em. We need all the help we can get.***

***The best gift for a Cub Scout.....  
.....get his parents involved!***

✓ ***Also, be sure to visit Bill's website***

<http://www.wtsmith.com/rt>

to finds more ideas on everything Cub Scouting.

***Have any [Comments for Bill](#)  
just click right here!***

## **PACK ADMIN HELPS**

### **Scout Week Display Pointers**

*Alice, Golden Empire Council*

- Contact a local business or library early to reserve time and space for a display; measure and record dimensions so you can plan your display. Make note of what day and time your display is to be put up and taken down.
- Plan a colorful display, with a good background, clear signage- avoid too much detail or small items. Ask a local artist or display specialist to help plan your display – you may have one in your pack family!



- Group items together – such as a Pinewood Derby racer, a trophy and an enlarged photo of Race day on one level in one area of the display.
- Consider using a theme for your display – it could be something simple, such as “Scouting Thru the Year” with large calendar pages listing a special activity for that month. It could also focus on some aspect of Scouting, such as “Scouting & Citizenship – a Community Resource” – use American and Pack flags as background and display large photos of service projects, examples of citizenship in action, marching in parades or putting out flags on Memorial Day.
- The story of Scouting in America would be a good theme, considering the American ABC theme for February- tell the story of how Scouting came to America, focus on specific American events and scouting culture.
- Use good signs – large computer lettering is very professional looking. Mount each sign on colored paper for greater impact. Be sure to have a very large sign if you have a specific theme – it could be done as a banner made on the computer. It could also be done by having the boys make a collage of scouting materials and photos from Boy’s Life to fill in large letters that spell out the theme – but put them on a plain background so they will stand out.
- Create different levels for your display – you can use boxes, but be sure to cover them with fabric or paper. Put taller levels to the back, but use varying heights and try putting them on the diagonal. This way, you can overlap and use the space more efficiently, and separate different events or ideas for greater impact.
- Think about where your display will be – if it is in a display case, think about what direction it will be viewed from. If people will be looking down on the display, you want to create a horizontal display that can be seen clearly from above. Make sure that the display looks good from any direction that can be seen – if the back side of boxes can be seen, they should be covered, for example.
- Arrive on time, with signage and all necessary equipment and materials, such as flags and flag stands, pins, tape, boxes or other equipment to create different levels. If you need a ladder, plan to bring it with you.
- Do a test run of putting up your display – tape out the dimensions of your space on the floor, then practice putting up the display and check to see if it looks good and can be understood. Make a diagram or take a picture so you will be able to recreate your display quickly in the actual site.
- Clean up the site before your leave, and be sure to thank the merchant or librarian for the opportunity.
- Advertise your participation – make sure pack families know about the display, and encourage them to patronize the merchant. Consider adding a poster with contact information for your pack, or if appropriate,

leave information about Scouting near your display. Be sure this is approved by the site manager.

- Invite the local newspaper to report on your displays, especially if you are having a contest – call them before you put up the display – they may prefer a picture of the actual work of creating the display.
- Be sure to make a photo of the completed display – show it off at the pack meeting or Blue & Gold, add it to the pack scrapbook, and give a copy to the merchant along with a thank you card!
- Don’t Forget – Take down your display on the agreed upon date and time! The merchant or librarian may have other displays waiting to be installed.

## SPECIAL OPPORTUNITY

### P.R.A.Y. HAS MOVED!

Effective January 1, 2009 their new mailing address is:

11123 S. Towne Square, Ste. B  
St. Louis, MO 63123-7816

Toll Free: 800-933-7729 (*no change*)

New Phone: 314-845-3318

New Fax: 314-845-0038

### Duty to God Promotion Patch

P.R.A.Y.

[www.praypub.org](http://www.praypub.org)

*I have attended the Religious conferences at the Philmont Training Center twice. Mark Hazlewood, the Director of P.R.A.Y., led one conference and helped at the other. It was great being with so many Scouters who wanted to help Scouts fulfill their Duty to God and strengthen their faiths. Mark and the organization at P.R.A.Y. have done a great job setting up this promotion effort. Their website and the DVD have everything – scripts, slideshows, FAQs, and other stuff. Lets get out there and make a difference. CD*

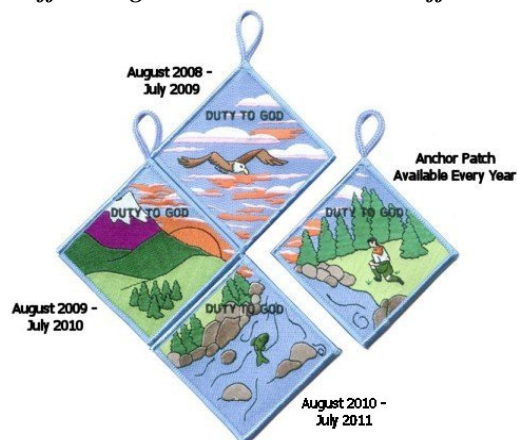

“Duty to God” is at the heart of the Scouting movement. Religious emblems reinforce this spiritual component and promote many of the values found in the Scouting program. The purpose of this “Duty to God Promotion Patch” is to encourage youth and adults to learn about and promote the religious emblems programs.

**Requirements –**

Youth and adults must:

1. Attend or coordinate a presentation or information seminar on religious emblems (sample resources and suggestions are available at [www.praypub.org](http://www.praypub.org) ).
2. Make a commitment to fulfill their "Duty to God."

Here are some examples:

- ✓ Adults can commit to having 50% of families participate in the religious emblems programs, nominating a worthy adult to be recognized with an adult religious award, serving as counselor in their local congregation, etc.
- ✓ Youth can commit to earning the religious emblem of their faith at an appropriate time, making a presentation on religious emblems to another unit, helping younger Scouts earn their religious emblem, etc.

**The Patch**

- ✓ The Duty to God Promotion Patch is a four-segment puzzle patch.
- ✓ Only one segment will be offered in any given year.
- ✓ Participants are encouraged to earn all four segments over a four-year span.
- ✓ Visit [www.praypub.org](http://www.praypub.org) to find out which patch is currently available.
- ✓ Patches may be pre-ordered for distribution at the presentation/ information seminar.

**The DVD**

The Duty to God Promotion DVD contains the resources to make a presentation on the religious emblems programs. These resources include the video "Promoting Duty to God (Religious Emblems)," Duty to God brochure/chart listing all religious emblems (No. 05-879), scripts (for presentations to Cub Scouts, Boy Scouts, and Venturers), and Parent Handout.

**Making a Presentation**

- ✓ Find scripts, videos, handouts, and other resources at [www.praypub.org](http://www.praypub.org)
- ✓ Invite parents
- ✓ Provide information on emblems of ALL faiths
- ✓ Encourage Scouts to make a commitment to earn their religious emblem
- ✓ Present the Duty to God Promotion Patch to participants

**Call and talk to the "Religious Emblems People" today!**  
1-800-933-7729 or visit them at [www.praypub.org](http://www.praypub.org)

**Knot of the Month**

*Have a Roundtable Commissioner and Unit Commissioner you think are great, see if they have earned their Doctorate of Commissioner Science. If so, help them along, fill out their paper to get them the honor they deserve! CD*

**Doctorate of Commissioner Science Award**

[www.usscouts.org](http://www.usscouts.org)

<http://scoutleaderawards.com/awards>



This square knot is presented to recognize completion of a standardized program leading to the completion of a thesis or project and the award of the Doctorate of Commissioner Science from a College of Commissioner Science.

**Justification**

The commissioner is the mainstay for Scouting program administration. It is commissioner service that ensures that units are healthy, productive, and assist in the growth of the program.

The College of Commissioner Science program is designed to have a commissioner learn, through a series of training classes, followed by work experiences to ensure a quality program throughout Scouting. This training will take a number of years to complete. The commissioner finalizes his/her training with an approved thesis or project for the benefit of the Scouting program. This assists both new commissioners as they learn, and seasoned commissioners as they train others.

A well-trained commissioner staff better serves the Scouting program.

The College of Commissioner Science program is a guideline for councils to adapt as they determine will fit their needs.

Having a knot award for the program requires that the commissioner complete, as a minimum, a training program standardized for all BSA programs.

**Objectives**

- ✓ To further involve commissioners in providing support to units in their delivery of a quality program experience for all youth in Scouting.
- ✓ To provide councils an opportunity to recognize commissioners for their tenured service, their involvement in learning more about delivery of quality Scouting, and their involvement in support of others.

**Requirements:****Tenure**

Serve as a commissioner for a minimum of 5 years. Their service can be in one or more commissioner roles or positions of service.

**Training****A. Bachelor of Commissioner Science Degree (BCS)****o Prerequisites**

1. Maintain registration in any capacity as a Commissioner during the entire training program listed below.
2. Complete Commissioner orientation (Commissioner Fieldbook)
3. Complete commissioner basic training.

**o Course Requirements**

Complete a minimum of seven (7) courses of instruction, at least five (5) of the courses at the Bachelor's program level as listed in the Continuing Education for Commissioners manual.

**o Performance**

1. Approval of Council or assigned Assistant Council Commissioner
2. Approval of Scout Executive or Advisor to Commissioner Service

**B. Master of Commissioner Science Degree (MCS)****o Prerequisites**

1. Completion of bachelor's degree.
2. Earned Arrowhead Honor.
3. Current registration as a commissioner.

**o Course Requirements**

Complete a minimum of seven (7) additional courses of instruction (total of 14), at least seven (7) of the courses at the Master's program level as listed in the Continuing Education for Commissioners manual.

**o Performance**

1. Approval of Council or assigned Assistant Council Commissioner
2. Approval of Scout Executive or Advisor to Commissioner Service

**C. Doctor of Commissioner Science Degree (DCS)****o Prerequisites**

1. Completion of master's degree.
2. Have been awarded the Commissioner's Key.
3. Current registration as a commissioner.

**o Course Requirements**

Complete a minimum of ten (10) additional courses of instruction not used to qualify for other college awards (total of 24), at least five (5) of the courses at the doctor's program level as listed in the Continuing Education for Commissioners manual.

**o Thesis or Project**

Completion of a thesis or project on any topic of value to Scouting in the local council. The topic and final paper or project must be approved by the council commissioner, or assigned assistant council commissioner, or the dean of the doctorate program and the staff advisor for commissioner service.

**o Performance**

1. Serve on the College of Commissioner Science faculty (instructor or support staff) or work with training support for commissioners for at least one year.
2. Recruit at least three new commissioners at any level.

3. Approval of Council or assigned Assistant Council Commissioner
4. Approval of Scout Executive or Advisor to Commissioner Service

**Grandfather or Sunset Clause:**

Anyone who earned their doctorate based on the qualifications listed above will not have to repeat what they have already completed, even if it was prior to 10 years ago. Just check with your local council on the procedure to follow.

**GATHERING ACTIVITIES**

*Note on Word Searches, Word Games, Mazes and such – In order to make these items fit in the two column format of Baloo's Bugle they are shrunk to a width of about 3 inches. Your Cubs probably need bigger pictures. You can get these by copying and pasting the picture from the Word version or clipping the picture in the Adobe (.pdf) version and then enlarging to page width. CD*

**PATRIOTIC SONG PUZZLE**

*Great Salt Lake Council*

Write the words to a patriotic song on strips of paper.

Let the boys put them in the right order.

Examples of songs include: The Star-Spangled Banner and America.

**State Flag Maze**

*Oregon Trail Council*

Copy this maze and enlarge it to fill a page

Paste your state flag over the Oregon flag if you wish

Have your Cubs solve the maze



Now where did I put that Oregon flag?

You can help... draw a path through the maze to help me remember.

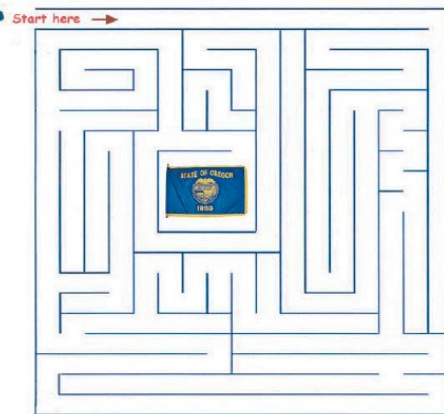

Find answer at:

<http://www.sos.state.or.us/bbook/kids/games/maze3.htm>

**Lost Landmarks**

*Sam Houston Area Council*

**Materials –**

Pictures of landmarks in the United States (or name typed out), and  
 Pictures of the associated states (or name typed out) where the landmarks are found.

*For example, the Alamo and Texas, Mount Rushmore and South Dakota, the Statue of Liberty and New York, Philmont and New Mexico, etc...*

**Directions –**

- ✓ As Scouts arrive, each is given either a landmark or a state.
- ✓ Scouts must find their partners.

**Do-It-Yourself Tablecloth**

*Oregon Trail Council*

**Materials:**

Paper on a roll,  
 Crayons or markers;  
 Prizes, if desired

**Directions**

- ✓ Cover tables with white butcher paper.
- ✓ Divide each table into four to six sections.
- ✓ At the center of each section, write a large alphabet letter.
- ✓ Challenge each table to come up with as many names of American towns, cities, states, counties, attractions, etc., as they can think of that begin with the letters on their table.
- ✓ They write their answers on the paper with crayons or markers.
- ✓ Prizes can be awarded for participation, longest list, most unique items, etc.

**Variation:** Make placemats with large alphabet letters in the center. Each individual can play as above.

**Map Puzzles**

*Oregon Trail Council*

- ✓ Before the meeting, create map puzzles by gluing old maps to cardboard backing,
- ✓ Then cutting them into puzzle pieces with a razor knife.
- ✓ Give each family a puzzle to put together.

**Capitol and States Boggle**

*Catalina Council*

1. Place all of the names of capitols of the United States in a container and have a cub scout draw out names until a grid 4 X 4 is completely filled up with letters of capitols or states.
2. It would be best to do this game on a chalk or grease board so that it may be changed often and regularly.
3. The object of the game is to see how many words the Cub Scouts can make up in a time frame of one minute.
4. The cub that has the most valid words wins.
5. Any words that are duplicated by another cub scout do not count - they cancel out each other.
6. Keep this game going until all the 50 states and their capitols have been used.
7. As one or the other is drawn say it out loud and see if any of the cub scouts can name the state to which it belongs.

8. The letters have to be touching and no letter can be used more than once in one word.
9. You can go diagonally, backwards, make angles so long as the letters are touching.
10. The following is an example: Capitols or States drawn: Salt Lake; Denver; Colorado Your grid would look like this:

S	A	L	T
L	A	K	E
D	E	N	V
E	R	C	O

Here are some of the words that I found in the grid-salt, lake, den, vet, red, nerd, as, Ankle, alas, real, lad, leader, ten, etc.

**American Heritage**

*Catalina Council*

- ✓ Make posters of well known buildings or symbols and put them up around the room.
- ✓ Number each poster.
- ✓ Give each person a numbered piece of paper.
- ✓ Ask them to identify the posters and write the proper name by its corresponding number on the sheet of paper.

**Suggestion are:** *American Flag, White House, Lincoln Memorial, Eagle, Presidential Seal, Uncle Sam, Statue of Liberty, Mount Rushmore, Stone Mountain, etc.*

**State Names and Capitals**

*Catalina Council*

- ✓ Copy an outline map of the United States so that you have one for each Cub Scout or one for each person at the pack meeting.
- ✓ People should write the name of each state and it's capital in the space for the state (or as close as possible to small states, with an arrow pointing to the appropriate state).
- ✓ After the meeting opens, reveal a large U.S. map for everyone to check answers.
- ✓ Give a prize to all who correctly identified the states and capitals.

**Other Methods:**

- ✓ Suggest that they write in any additional information they know, such as the state bird, flower, tree, song, or nickname.
- ✓ People write their names on the papers and turn them in.
- ✓ A leader or other adult uses a list, an encyclopedia, or other reference book about the United States to check the papers.
- ✓ Give a prize to the one with most correct answers.

**AMERICA**

*Great Salt Lake Council*

Write the word AMERICA down the page and write one word beginning with each letter that describes America.



*Or do it this way -*

**American ABC's -Can You Name Them?**

*Catalina Council*

- ✎ Give everyone a sheet of paper with the letters A to Z going down the left side.
- ✎ Tell them to write one American place or thing for each letter from A to Z.

*Or do it this way -*

**STATE ABCS**

*Great Salt Lake Council*

Using maps and atlases, have the Scouts and families find one geographical location for each letter of the alphabet. Examples: Arizona, Baltimore, Columbia River, Denver, etc.

**GRAND "NEW" FLAG**

*Great Salt Lake Council*

- ✎ Provide boys with crayons and paper so everyone can design a NEW American Flag.
- ✎ Have them explain the symbolism behind their new flag.

**AMERICA PUZZLE**

*Great Salt Lake Council*

- ✓ Cut out large versions of the letters in America.
- ✓ Cut the letters into pieces creating a puzzle and
- ✓ Place the pieces in a bag.
- ✓ Give each boy or group a letter and have them put their letters together.
- ✓ Then as a whole put your letters together to form "America. "

**Who, What, Where, and When?**

*Alice, Golden Empire Council*

Display scenes from around the United States, pictures of famous Americans, or historical objects from American History – each one should be numbered, but not identified.

As families arrive, they are given a sheet of paper with the numbers along the left side. They must work together to identify each item by name or location.

**Which State, Which Motto?**

*Alice, Golden Empire Council*

Can you match up these mottos with correct states?

<b>Motto</b>	<b>State</b>
North to the Future	Indiana
Live Free or Die	Minnesota
The North Star	Arkansas
Gold & Silver	California
Eureka	Montana
Liberty & Prosperity	Kentucky
The People Rule	Alaska
United we stand, divided we fall	New Jersey
The Crossroads of America	West Virginia
Mountaineers are always free	Maine
Dirigo (I lead)	New Hampshire

[www.infoplease.com/ipa/A0801718.html](http://www.infoplease.com/ipa/A0801718.html) has a list of all state mottos – be sure to include your own state in your game!

**STATES LETTER GAME**

*Great Salt Lake Council*

Give each participant or pair a paper listing the first letter of the name of each state in the US. Have them write each state on the blanks. Provide a blank map if this helps.

**Spell It Out**

*Catalina Council*

**Equipment:** Pencil and Paper

**Directions:**

1. Give the Cubs a phrase made up of two or three words.
2. From that phrase, the Cubs must come up with as many words as possible. Challenge them by making them think of words only with "B", or "S", or "D," or limit them to just three letter words or four letter words.
3. Use a phrase that is common to your pack or den.

Perhaps:

INDEPENDENCE DAY or PRESIDENTS DAY

**Famous Scenes – A to Z**

*Alice, Golden Empire Council*

Give each person, family or den a paper with the letters A to Z along the left side –

Winner comes up with the most American scenes, such as: Grand Canyon, Golden Gate Bridge; Mount Rushmore, Monticello; Statue of Liberty, Smithsonian; Washington Monument; Yukon, Yellowstone National Park

**OPENING CEREMONIES**

**Learning our A B C's**

*Sam Houston Area Council*

**Setting** – 6 Cub Scouts, Cubmaster (CM), poster board with A-B-C-D-E-F on the front and the appropriate verse on the back in LARGE print.

**Scene** – Scouts walk across stage and as they approach the center or the Cubmaster, each holds up his letter and shouts his message.

**Cub # 1:** A Aims and Methods

**Cub # 2:** B Boys!

**Cub # 3:** C Character Connections and Citizenship

**Cub # 4:** D Developing Skills

**Cub # 5:** E Expeditions and Electives

**Cub # 6:** F Fitness

**CM** This is only the beginning of the remarkable things Cub Scouts discover as part of our program. Let's take some time at our pack meeting this evening to see if we can find some other ABC's. But for now, I ask you to stand and please join me in the Pledge of Allegiance.

**America, the Greatest Country in the World***Sam Houston Area Council***Setting** – 7 Cub Scouts, Cubmaster (CM)**Scene** – Cubs in a line next to the flag.

**CM** The Cub Scout promises to do his duty to his country. We would like to review for you some of the things that are different but that make us the greatest country in the world.

**Cub # 1:** We call it the United States and we're bound together by our Constitution and our language. Yet in many ways, we're a group of separate kingdoms.

**Cub # 2:** We practice more than 250 different religions and observe thousands of different hunting laws, tax laws, and labor laws.

**Cub # 3:** Our land grows palm trees and pine trees, redwoods and beech trees, plum trees and apple trees.

**Cub # 4:** Our citizens say "Hello" and "Hi" and "Howdy!"

**Cub # 5:** We catch shrimp and sell stocks – live in small houses, sky-scrappers, apartments, and stucco bungalows.

**Cub # 6:** We are a very diverse land, but these are some of the things that make the United States great!

**Cub # 7:** Please rise and join us in the Pledge of Allegiance.

**America is a Beautiful Word***Catalina Council***Personnel:** Narrator and 7 Cub Scouts

**Equipment:** Each boy holds a card with a letter of "AMERICA" on it. Flip card over and draw a picture with the same letter illustrating the description below.

**Narrator:** What do you see when you look at the word AMERICA? What mental picture do the seven letters create in your mind?

**Cub # 1:** The "Capital A" suggest our magnificent snow-covered mountain peaks, and the wigwams of the original Americans.

**Cub # 2:** The "M" symbolizes the broad shoulders of our pioneer, shoulder-to-the-wheel pushing our frontier westward; broad shoulder swinging axes, building a nation.

**Cub # 3:** The "E" might be the lariats of the cowboy riding the plains, lariats of Kit Carson or Buffalo Bill.

**Cub # 4:** The "R" is a man with outstretched arms in friendship and cooperation toward all who love freedom, justice and peace.

**Cub # 5:** The "I" represents the individual American with his right to life, liberty, and the pursuit of happiness.

**Cub # 6:** The "C" is a bent bow from which an arrow has just sped toward the heart of mankind's greatest ideals.

**Cub # 7:** The final "A" is a man on his knees in prayer, symbolizing a nation which recognizes it's Creator and gives thanks for His blessings.

**Narrator:** Yes, America is a beautiful word! Let us rise and make the Pledge of Allegiance.

**Story of the Blue and Gold***Great Salt Lake Council***Preparation:**

- Put a large pot on a table with an inner pot containing dry ice.
- A blue and gold Wolf Cub Scout neckerchief is concealed in the area between the large pot and the inner pot.
- Have two clean jars concealed elsewhere close by. One has blue colored water and the other yellow-colored water.

**Cubmaster:** Many, many years ago, an elder gave two trusted young men a challenge. He told the first young man to climb the mountain and ask the great eagle to fly high into the sky. His mission was to bring back part of the beauty of the sun. (The first Cub Scout leaves.)

He told the second young man to go into the forest and tell the sparrow to fly into the sky and bring back part of the sky. (The second Cub Scout leaves.)

Then both boys return—one carrying a bottle of yellow-colored water and the second carrying a bottle of blue-colored water. (They hold them up for all to see.)

*(To the first boy:)* Pour some of the beauty of the sun into our mixing pot. (The boy carefully pours the yellow liquid over the dry ice.)

*(To the second boy:)* Pour some of the beauty of the sky into our mixing pot. (The second boy carefully pours his blue water into the pot.)

*(To the pack:)* From this day forward, blue will stand for truth and loyalty. Yellow will stand for warm sunshine, happiness, and good cheer. (Reaches into the pot, removes the blue and gold Wolf neckerchief and opens it for all to see.) And that is why the Cub Scouts use the colors blue and gold.

**Red, White & Blue Over Blue & Gold***Catalina Council**adapted from Scouting Magazine*

**Staging:** Flag in stand on table, under which "voice" is concealed. Or have flag posted near screen concealing "voice." Cub Scout in uniform walks by flag and stops when flag starts to "speak."

**Flag:** Hey, Cub Scout!

**Cub:** Who's that?

**Flag:** Me, your flag.

**Cub:** What's the matter?

**Flag:** Well, I'm taken lots of places, but, why am I here?

**Cub:** But, we take you everywhere with us. we carry you proudly even in our hearts. The Scout program has taught me to respect the flag and to love my country.

**Flag:** But, what is all the festivity?

Why would you bring me here?

**Cub:** This is our Blue & Gold Banquet.

All the Cub Scouts get together once a year with their families to recognize another anniversary of scouting. In doing this, it gives us all a renewed sense of certainty and confidence in the future of our country.

**Flag:** Scouting! Yes, there is hope after all, but why am I here?

**Cub:** But, don't you know? Why, you are the guest of honor! Without you and what you represent we couldn't have Scouting at all!

**Flag:** Thank you, Scout!

**Cub:** (Salutes) Any Time! (Walks offstage) -

### Explanation of the Pledge of Allegiance

*Great Salt Lake Council*

Preparation: Cubmaster (CM) and eight Cub Scouts memorize lines to recite from the Pledge of Allegiance.

**CM:** We often recite the Pledge of Allegiance without really listening to or understanding the words we are saying. We will recite it and talk about the meaning of each phrase.

**Cub # 1:** I pledge allegiance...

**CM:** I, an individual, promise my love, devotion, and loyalty.

**Cub # 2:** To the flag of the United States of America...

**CM:** It is the symbol of 50 great states that have a common bond.

**Cub # 3:** And to the republic for which it stands...

**CM:** Representatives are chosen by the people to govern themselves in a republic.

**Cub # 4:** One nation under God...

**CM:** We are one nation under God and blessed by God. There is no pause after nation. It is said as one complete phrase—one nation under God.

**Cub # 5:** Indivisible...

**CM:** It is incapable of being divided.

**Cub # 6:** With liberty...

**CM:** With freedom and the right to live your own life the way you wish.

**Cub # 7:** And justice...

**CM:** Dealing fairly with others.

**Cub # 8:** For all.

**CM:** Everyone—it is your country as much as it is mine. Please stand and repeat the Pledge of Allegiance with us.

### Flag Ceremony - Freedom

*Catalina Council*

#### Setting:

With lights low have a large flag held by Cub Scouts. Have 8 Cub Scouts with flashlights to shine on the flag as an off-stage, hidden narrator reads.

#### Narrator:

I am your American Flag. I am the flag of this great United States.

I stand for the past, the present and future of this country of yours.

I represent your freedoms - - -

★ The freedom of speech (The 1st Cub turns his flashlight on)

★ The freedom of religion (2nd Cub Scout lights flashlight)

★ The freedom of the press (3rd light)

★ The freedom of job (4th light)

★ The freedom to vote (5th light)

★ The freedom to assemble (6th light)

★ The freedom of trial by jury (7th light)

★ The freedom of self-government (8th light)

If we allow any of these freedoms to be taken away, our nation would be a dreary place to be.

Let's all do our part to be good citizens.

**Cubmaster:** Lets all stand and make the Pledge of Allegiance and then sing God Bless America (*or another patriotic song of your choice*)

### This Is My Flag

*Baltimore Area Council*

**CM:** This is my flag, the flag of the United States of America, home of liberty, land of opportunity, where men of all races, creeds live in peace and friendship together.

**Ldr #1:** (Turns red light on flag) The red of my flag is the lifeblood of brave men ready to die or worthily live for this, our country.

**Ldr #2:** (Turns white light on flag) The white of my flag is for purity, cleanliness of purpose, thought and deed.

**Ldr #3:** (Turns blue light on flag) The blue of my flag for faith and loyalty, like the eternal blue of the star-filled heavens.

**Ldr #4:** The Cub Scout promises to "Do his duty to his country." Ours is different in many ways from other countries. We would like to review for you some of the things that are different but which make this the greatest country in the world.

**Cub # 1:** We call it the United States, and we're bound together by our Constitution and our language. Yet in many ways we're a group of separate kingdoms.

**Cub # 2:** We practice more than 250 different religions and observe thousands of different hunting laws, tax laws and labor laws.

**Cub # 3:** Our land grows palm trees and pines; redwoods and beach plum; vanishing key deer and whooping cranes.

**Cub # 4:** We catch shrimp and sell stocks; live in lean-to's, skyscrapers, and stucco bungalows.

**Cub # 5:** Our people say "you all" and "youse".

**Cub # 6:** We are a very diverse land, but these are some of the things that make the United States great.

**Cub # 7:** Will everyone stand and join with us in the Pledge of Allegiance to the United States flag?

**Red, White & Blue Bird**

*Catalina Council*

**Personnel:** Cubmaster (CM), Assistant Cubmaster (CA) and 2 Den Leaders (DL)

**Equipment:** Camping gear and outfit for each participant, 1 binoculars, American Flag, and Pack Flag

**Setting:** The Flags are in front of the audience. The group of participants are off to one side and slowly walk through the audience to the front, as they say their line.

**CM:** (Everyone starts walking slowly) It sure is nice to be here in the outdoors. All these trees, animals and fresh air.

**CA:** (looking through binoculars) Hey, I think I see a big red bird up there!

**DL 1:** (Takes the binoculars away as everyone continues to walk slowly toward the front) Here, let **ME** see! Naw, it's a huge white bird of some sort.

**DL 2:** (Takes the binoculars away while everyone continues to walk slowly to the front) Boy, you don't know what you're talking about! It's not red OR white. It's big and blue and what's this?!?!?! It has STARS!!

**CM:** (Cubmaster takes the binoculars and everyone STOPS) Here, let ME see what you're all talking about. (Looks through the binoculars) C'mon you guys. (Motions for everyone to follow as they walk to the front) It's not a red bird, or even a white bird. What you are looking at is our nation's flag! (Turns to audience) Please rise and join us in the Pledge of Allegiance.

**AUDIENCE PARTICIPATIONS**

**The Transcontinental Train**

*Sam Houston Area Council*

Divide the audience into 6 groups. Assign each group one of the words listed below. When their item is mentioned in the story, the assigned group should shout the designated saying. Have a practice session before starting the story.

TRAIN	"Toot Toot"
CONDUCTOR	"All Aboard!"
NEW YORK DOCTOR	"The Big Apple!"
STEEL WORKER	"Forged in Steel!"
ST. LOUIS BUSINESSMAN	"Gateway to the West!"
KANSAS FARMER	"Breadbasket to the World!"

Just before the transcontinental TRAIN pulled out of Grand Central Station in New York City, the CONDUCTOR held the door for one more passenger, a NEW YORK DOCTOR who hurried aboard. The TRAIN moved slowly between the tall buildings, out of New York State, through New Jersey and on to Pennsylvania. The CONDUCTOR checked the ticket of the NEW YORK DOCTOR as the TRAIN pulled into the Pittsburgh Station. A Pennsylvania STEEL WORKER boarded the TRAIN and sat across the aisle from the NEW YORK DOCTOR.

Climbing through the Allegheny Mountains, the TRAIN continued past rivers and forests across the Midwest to St Louis, Missouri. The CONDUCTOR greeted a ST. LOUIS

BUSINESSMAN who boarded the TRAIN at Union Station. The ST. LOUIS BUSINESSMAN smiled at the STEEL WORKER, and sat behind the NEW YORK DOCTOR. The TRAIN picked up speed as it passed the Gateway Arch. The CONDUCTOR paused to look out the window with the STEEL WORKER as the TRAIN traversed a long bridge over the Mississippi River. It made its way to Kansas City where a KANSAS FARMER boarded the TRAIN. The KANSAS FARMER greeted the STEEL WORKER and shook hands with the NEW YORK DOCTOR and then sat beside the ST. LOUIS BUSINESSMAN.

Continuing west, the TRAIN moved up steep mountain passes and through the snow-covered Rocky Mountains of Colorado and Utah. The CONDUCTOR checked his watch as the TRAIN sped out of the mountains and into the desert of the Great Basin in Nevada. The passengers watched the vast landscape as the TRAIN sped by.

The ST. LOUIS BUSINESSMAN and the NEW YORK DOCTOR admired the large trees, as the TRAIN wound through the Sierra Nevada Mountains and the Redwood forests. The transcontinental TRAIN pulled into its final destination of San Francisco, California. It had made its way from east to west, from coast to coast. After this long journey it was time for the CONDUCTOR to say "Good-bye" to the tired travelers: the NEW YORK DOCTOR, the Pennsylvania STEEL WORKER, the ST. LOUIS BUSINESSMAN, and the KANSAS FARMER. The TRAIN had made a very successful trip.

**LEADER RECOGNITION**

**A Den Leader's PayDay**

*Professor Beaver's Site*

[http://www.usscouts.org/profbvr/fun\\_awards/index.html](http://www.usscouts.org/profbvr/fun_awards/index.html)

*Write this out putting the candy (or a wrapper from the candy or a picture of the candy) where you see \*)*

Sometimes we were **Butterfingers\***

But always a **Joy\***

We always did **Snicker\***

After all, we are boys.

We wanted to give you **\$100,000 Grand\***

But had **Zero\*** money

So that idea was canned.

We **M & M\***ade you this card

With **Mounds\*** of love and rhyme

To thank you for giving up

so much of your time.

*Put in a row of Hershey Hugs and Kisses and have the Cubs sign it. I used poster board for mounting the candy and a calligraphy pen for printing the poem. Prof Beaver*



**The ABCs of Leaders**  
*Sam Houston Area Council*

Great Cub Scout Leaders –

- A - Attend** Roundtable
- B - Believe** in the program
- C - Call** to check up if you miss a den meeting
- D - Discover** new ways to involve the Scouts
- E - Explore** all the options
- F - Find** time
- G - Give** unconditionally
- H - Help** whenever asked
- I - Inspire**
- J - Juggle** lots of projects
- K - Know** their knots
- L - Listen**
- M - Make** extra project pieces for siblings
- N - Notice** the wonderful things about their Cub Scouts
- O - Offer** support
- P - Pray**
- Q - Quote** Lord Baden-Powell
- R - Reap** the rewards of Cub Scout smiles
- S - Sing!**
- T - Tell** their Scouts – “great job!”
- U - Understand** that life happens
- V - Value** the Aims of Scouting
- W - Wake** up in sleeping bags
- X - X-amine** all material for appropriateness
- Y - Yell** cheers during pack meetings
- Z - Have a Zany** disposition

*Here's another version - CD*

**Awards from the Heart**  
*Oregon Trail Council*

Everyone needs a pat on the back to feel appreciated! These awards are quick and easy. Remember to award den chiefs, pack leaders, and parents, too. Be sure to mention specifically what the person is being recognized for.

**Monu-MINT-al Award**

Attach a mint to a note or certificate stating that the person has made a monu-mint-al contribution to Scouting.

**We Are Not STRETCHING It – We Appreciate You!**

Mount rubber bands on foam board or mat board.

**You Are Tops**

Award a toy top

**You Rose to the Occasion!**

Award a plastic rose.

**What a Catch!**

Award a certificate with a fish picture or plastic fish.

**You Have Been the Link to Success**

Award links of a chain.

**There are many lists like this on the internet -**

Professor Beaver's site has lighthearted, fun award ideas  
[http://www.usscouts.org/profbvr/fun\\_awards/index.html](http://www.usscouts.org/profbvr/fun_awards/index.html)

Try some searches - "101 ways to recognize," scout leader recognition

**The ABC's Of Being An Effective Leader**  
*Catalina Council*

- ★ **A – Attitude:** accent the positive, attitudes determine effectiveness
- ★ **B – Boys:** remember the program is for them
- ★ **C – Communications:** help keep the lines open
- ★ **D – Diplomacy:** be a diplomat, always put your best foot forward
- ★ **E – Effort:** you'll get out as much as you put in
- ★ **F – Flexibility:** to be able to change and adapt
- ★ **G – Guide:** guide, but don't force
- ★ **H – Harmony:** you can help maintain this in your pack
- ★ **I – Interest:** keep interest high by KISMIF (Keep It Simple, Make It Fun)
- ★ **J – Joy:** spread it, pass it on
- ★ **K – Knowledge:** Cub Scouts depend on you for this – stay informed
- ★ **L – Listen:** with understanding
- ★ **M – Morale:** keep your spirits high
- ★ **N – Nobody:** is a nobody in Cub Scouting
- ★ **– Organized:** set goals and reach them
- ★ **P – Problems:** there are none...just look at them as unresolved opportunities
- ★ **Q – Quandary:** keep yourself out of this state
- ★ **R – Resourceful:** know where to get materials and ideas
- ★ **S – Scout:** our goal is for every Bobcat to become an Eagle Scout
- ★ **T – Training:** be sure to keep yourself up-to-date
- ★ **U – Uniform:** promote the uniform and set a good example by wearing it
- ★ **V – Volunteers:** that's most of us in the Cub Scout program, try to recruit others
- ★ **W – Wisdom:** this includes perseverance, tolerance and tact.
- ★ **X – Xtra Special:** each Cub Scout is definitely that
- ★ **Y – Year:** Cub Scouting is year-round and plan your program that way
- Z – Zest:** perform your job with it

**Exceptional Award**

*Sam Houston Area Council*

**Materials** – Block letter E mounted on a display with the wording – for your exceptional help, many thanks!

**Cubmaster (or Committee Chair)** – There are many parents and leaders here tonight who have helped our pack in a variety of ways. They have contributed their time to the success of our pack meeting and they deserve the Exceptional award for seeing projects and meetings and lots of other things through from a to z. (Call adults forward and present awards.)

**Leader Recognition Ceremony**

*Baltimore Area Council*

**Cubmaster:** Tonight, I would like to recognize one of our Den Leaders that completed the requirements for the Den Leader Award. Will \_\_\_\_\_ please come forward. We want you to know that we appreciate all the time and effort that you put forth. You are helping shape these boys lives and building leaders of tomorrow. I would like to present to you the Den Leader's Award Certificate and Square Knot that you can wear on your uniform.

## ADVANCEMENT CEREMONIES

### Favorite Places Advancement Ceremony Sam Houston Area Council

#### Materials –

- Large map of the US mounted on cardboard.
- Cut out Scout figures and string across the map.
- Awards are mounted on the figures.
- Each Scout earning an award should be prepared with a picture of one of his favorite places in America. It can be a place he visited on vacation, where he used to live, where he would like to live, or of where he now lives.

**Cubmaster:** This month we have been learning about the beauty and variety in our nation. We have several boys who have earned awards as you can see by our interesting map. (Name of boy), you have earned your Bobcat Rank this month. Would you please come forward and show us the picture of one of your favorite places?

(Scout comes forward, shows picture and says where it is and why he likes it.

Cubmaster then invites parents to come up while he takes the picture and posts it on the map.

Present award to parents to give to Scout.

*Continue with other awards in the same way.)*

**Cubmaster:** Now that we have added pictures of all these beautiful places, our map is much more than just a piece of paper on the wall. It is special to each of us. There are beautiful things about each and every place we might live. It is up to us to find that beauty. But the most beautiful part of any place is the people who live there. We must also look for the beauty in others. If we can do that, wherever we live will be our favorite and the most beautiful place to be.

#### Presidents

*Catalina Council*

**Personnel:** 5 adult readers and Cubmaster (CM).

**Equipment:** Picture of the president or a sign with the name of the President can be held up by one person.

**Rdr 1:** George Washington, the Father of our country, and first president, used to say, “Martha, where are my teeth? I must have a good smile this day.

**Rdr 2:** Thomas Jefferson, our third president always felt he learned his lesson, because he never again wrote another Constitution, having said, “I’ve written it once. I’ll not write it again.”

**Rdr 3:** Andrew Jackson fought in the Louisiana Territory and fought his way to the White House. He’d often say, “Where’s my horse? I can’t get anywhere without my horse!”

**Rdr 4:** Abraham Lincoln is said to have walked 20 miles to school, but no one ever said if he was late.

**Rdr 5:** Ronald Reagan got to the White House by being unique - an actor - and one of the only left-handed cowboys, except for Little Joe Cartwright.

**CM:** Each had a goal. And tonight, we honor boys who have achieved their goal, too. But to receive the

goal you must name a President before coming forward to get your award. (Parents may help when needed.)

### USA ADVANCEMENT CEREMONY Great Salt Lake Council



Before Pack meeting pin a large U.S. Map on a board or wall. As each Cub Scout enters for the pack meeting they will put their name on a piece of 8 1/2 by 11 inch sheet of paper. The Cub Scout will fold and make a paper airplane out of it. They will then attach the plane to any state they want on the map. The Cubmaster will randomly select a plane from the map and will then call out the Cub’s name to receive his award. After the Cub Scout receives his award, the Cubmaster will ask the Cub one question about what he knows about that state. That Cub will then select the next plane to be taken down. When the awards are finished the Cubmaster will say, “You are just one Cub of the Millions of Cub Scouts across the United States. As a Cub Scout, always remember to ‘Do Your Best’.”

#### Presidential Award Ceremony

*Catalina Council & Baloo*

*This is an old ceremony I used for my pack back in the early 1990's. And I still love it today. Originally, I found it in "Staging Den and Pack ceremonies" but it is not there anymore (or it would have a Tiger section). So I jumped in and added a section for the Tigers. I chose Monroe but the words speak about the partners not the boy. I am open for other ideas for a President for Tigers. CD*

**Props –** Large pictures of George Washington, James Monroe, Thomas Jefferson, Theodore Roosevelt, John Kennedy, Abraham Lincoln, and Gerald Ford

**Cubmaster –** We are proud of the outstanding Presidents who have been so important to our Country’s Heritage. We are especially proud of our Cub Scouts and Webelos Scouts who are learning new skills and ideals that will help them later in life. It is likely that some of these Scouts will become outstanding in American History some day. Many of our well-known American figures were Scouts when they were young.!

**Assistant Cubmaster** The first step in Cub Scouting is the Bobcat Award. We symbolize this with our first president, George Washington. (Have Cub Scout hold up picture of Washington) Just as earning the Bobcat is important in getting a boy started on the Cub Scout trail, our first President was important in getting our country started off

right. Our Bobcats are starting off correctly working with their parents to earn this award. *(Call forward Bobcats and their parents. Present Bobcat patches to parents who will present them to their sons. Do other ceremonial rituals your Pack may have.)* Congratulations! Lead Cheer!!

**Tiger Cub Den Leader** The next step in Cub Scouting is the rank of Tiger. We symbolize this with James Monroe, our fifth president. *(Have Cub Scout hold up picture of Monroe)* Just as the Adult Partners are important in helping our newest Cub Scouts along the Tiger Cub trail, President Monroe was important in helping the new republics in Central and South America get started off right. He played a role similar to our Tiger Cub's Adult partner for these new republics when he established the Monroe Doctrine and had the USA provide them protection. *(Call forward Tiger Cubs and their partners. Present awards to parents who will present them to their sons. Do other ceremonial rituals your Pack may have.)* Congratulations! Lead Cheer!!

**Wolf Den Leader** – Next is the rank of Wolf. We will symbolize this rank with Thomas Jefferson, the author of the Declaration of Independence. When a boy becomes a Wolf, he demonstrates more independence than when he was a Bobcat. He demonstrates this by sometimes working on his own achievements and electives. *(Call forward boys to receive Wolf Badges and Arrow Points. Call their parents, too. Present badges to parents who will present them to their sons. Do other ceremonial rituals your Pack may have.)* Congratulations! Lead Cheer!!

**Bear Den Leader** – When a Cub Scout reaches Bear, he has learned much from the challenging projects he completed. To symbolize the Bear Rank we use Teddy Roosevelt, for whom Camp Roosevelt is named. He is another outstanding President. Teddy Roosevelt accepted many challenges during his life. *(Call forward boys to receive Bear Badges and Arrow Points. Call their parents, too. Present badges to parents who will present them to their sons. Do other ceremonial rituals your Pack may have.)* Congratulations! Lead Cheer!!

**Webelos Leader** – When a boy joins a Webelos Den, he is ready to work on Activity Badges, which are more challenging than Achievements and Electives. We symbolize this with an outstanding president, Abraham Lincoln, who started as a poor boy in a log cabin and became the 16<sup>th</sup> President of the United States. These are Scouts who have worked their way from Bobcat to Webelos Den. *(This is a graduation to the Webelos Den. Call forward boys to receive Webelos Neckerchiefs, Colors, books and/or whatever you present to Scouts as they move to the Webelos Den. Call their parents, too. Present to parents who will present them to their sons.)* Congratulations! Lead Cheer!!

**Webelos Leader** – Webelos Scouts work on Activity Badges that help them learn about many new interests and pave the way for future Scouting. Webelos Scouts learn more about the outdoors and go on overnight camping trips with their adult partners. We symbolize the Activity Badges with John F. Kennedy, who believed in physical fitness and loved the outdoors. *(Call forward boys to receive Activity Badges. Call their parents, too. Present Activity Badges to*

*parents who will present them to their sons. Have one Scout say a few words about each badge presented.)*

Congratulations! Lead Cheer!!

**Cubmaster or Webelos Leader** – As the Webelos Scout progresses toward being a Boy Scout, he may earn the Webelos Badge by having an adult family member read and sign the Parent Guide in his Webelos Book, by being active in the den for three months, by explaining the meaning of the Webelos Badge, by explaining the parts of the Webelos uniform, by earning Fitness and two other Activity badges, by planning and leading a flag ceremony in his den, by understanding the requirements to become a Boy Scout, and by becoming actively involved in his religious faith. We symbolize this area of Scouting with Gerald Ford, who was the first president to earn the rank of Eagle as a youth. *(Call forward boys to receive Webelos Badges. Call their parents, too. Present to parents who will present them to their sons. Do other ceremonial rituals your Pack may have.)* Congratulations! Lead Cheer!!

## SONGS

### The Travel Song

Sam Houston Area Council

Tune - BINGO

If you like rodeos and horses  
Then you should visit here;  
T-E-X-A-S, T-E-X-A-S, T-E-X-A-S  
And shout a loud yee-haw!

If you like syrup from maple trees  
Then you should visit here;  
M-A-I-N-E, M-A-I-N-E, M-A-I-N-E  
Just watch out for the cold.

If you like farms that grow potatoes  
Then you should visit here;  
I-D-A-H-O, I-D-A-H-O, I-D-A-H-O  
At all three meals, what fun!

If you like seeing whales and glaciers  
Then you should visit here;  
A-L-AS-K-A, A-L-AS-K-A, A-L-AS-K-A  
And pack an extra jacket.

For fun and adventure all around  
You should visit someplace here  
The Great-U-S-of-A, The Great-U-S-of-A, The Great-U-S-of-A  
And share your Scouting spirit.

### You're a Grand Old Flag

by George M. Cohan

Sam Houston Area Council

You're a grand old flag,  
You're a high flying flag  
And forever in peace may you wave.  
You're the emblem of  
The land I love.  
The home of the free and the brave.  
Ev'ry heart beats true  
'neath the Red, White and Blue,  
Where there's never a boast or brag.  
Should auld acquaintance be forgot,  
Keep your eye on the grand old flag.

**Up The Cub Scout Mountain***Sam Houston Area Council*

Tune – Clementine

Rocky Mountains, Appalachians,  
 And Sierras reaching high.  
 Cub Scouts climbing up the mountain  
 Striving hard to reach the sky.  
 First the Tigers, with their parents,  
 Learning as they climb along.  
 Then the Wolf den hits the Cub trail,  
 Hear them as they sing their song.  
 Now the Bears are climbing upward,  
 Heading up the trail they chose.  
 As they climb their hearts are set on  
 Their next hike as Webelos.

**Where Shall We Visit Today?***Sam Houston Area Council*

Tune – Home on the Range

Oh give me a train, or a boat, or a plane,  
 That will carry us Cubs far away.  
 To Orlando or Nome, let us wander and roam,  
 And find new things to do every day.

**Chorus:**

Hike, hike on a trail,  
 Or float over waves all the day,  
 Or soar through the clouds, far over the crowds,  
 But be home before dinner each day.

In a row boat we'll glide, to see the Chesapeake tide,  
 Take a trip to Seattle to fish.  
 Our adventure is great, so be sure to save the date,  
 And we can go anywhere that we wish.

**Chorus**

Oh, the San Diego zoo, is looking good too,  
 How about a climb up to Pike's Peak?  
 Or deep on the floor, the Great Salt Lake to explore,  
 Cub Scouting journeys are always a treat!

**If Your Name Starts With....***Northwest Suburban Council*

tune: If You're Happy and You Know It

If your name starts with **A** turn around.  
 If your name starts with **B** touch the ground.  
 If your name starts with **C** then stand up and touch your knee.  
 Clap your hands if your name starts with **D**.  
 If your name starts with **E**, wink your eye.  
 If your name starts with **F**, try to fly.  
 If your name starts with **G**, blow a kiss up here to me.  
 If your name starts with **H**, say, "Hee, Hee."  
 If your name starts with **I**, hop in place.  
 If your name starts with **J**, pat your face.  
 If your name starts with **K**, kneel down and stay  
 If your name starts with **L**, shout, "Hooray!"  
 If your name starts with **M**, make me smile.  
 If your name starts with **N**, shake awhile.  
 If your name starts with **O**, put your elbow on your toe.  
 If your name starts with **P**, say, "I know."

If your name starts with **Q**, raise your hand.  
 If your name starts with **R**, you should stand.  
 If your name starts with **S**, you should pat your head, I guess.  
 If your name starts with **T**, say, "Oh, yes!"  
 If your name starts with **U**, touch your eye.  
 If your name starts with **V**, pat your thigh.  
 If your name starts with **W,X,Y or Z**,  
 Then stand up a take a bow and say, "That's me!"

**You're a Grand Old Flag**

by George M. Cohan

*Sam Houston Area Council*

You're a grand old flag,  
 You're a high flying flag  
 And forever in peace may you wave.  
 You're the emblem of  
 The land I love.  
 The home of the free and the brave.  
 Ev'ry heart beats true  
 'neath the Red, White and Blue,  
 Where there's never a boast or brag.  
 Should auld acquaintance be forgot,  
 Keep your eye on the grand old flag.

**What Did Delaware, Boys?***Catalina Council*

Oh, what did Delaware, boys, oh, what did Delaware?  
 Oh, what did Delaware, boys, oh, what did Delaware?  
 Oh, what did Delaware, boys, oh, what did Delaware?  
 I ask you now as a personal friend, what did Delaware?  
 She wore her New Jersey, boys, she wore her New Jersey.  
 She wore her New Jersey, boys, she wore her New Jersey.  
 She wore her New Jersey, boys, she wore her New Jersey.  
 I tell you now as a personal friend, she wore her New Jersey.

**Continue verses with other states:**

Florida: Oh, how did FLORI-DIE (Flora die), boys?  
 Missouri: She died in MISSOURI (misery), boys.  
 Iowa: Oh, what does IO-WA (Io weigh), boys?  
 Washington: She weighs a WASHING-TON, boys.  
 Idaho: Oh, what does IDA-HO (Ida hoe), boys?  
 Maryland: She hoes her MARY-LAND, boys.  
 Tennessee: Oh, what does TENNES-SEE, boys?  
 Arkansas: She sees what ARKAN-SAS (Arkan saw), boys.  
 Oregon: Oh, where has ORE-Gon (Ore-gone), boys?  
 Okla: She's gone to OKLA-HOMA (Okla-home-a), boys.  
 Massachusetts: Oh, what did MASSA-CHEW, boys?  
 Connecticut: She chewed her CONNECTI-CUD, boys.

**Boldly Flies Our Flag***Baltimore Area Council*

(Tune: Scout Vesper)

Boldly flies our flag this day,  
 Cause of brave men's deeds displayed,  
 Freedoms backed by worlds so strong,  
 Written by forefathers gone,  
 We stand up straight and true and proud,  
 Hand salute old glory now,  
 Red & white, a field of blue,  
 50 stars that shine so true.



**When I See The Flag***Baltimore Area Council*

(Tune: Amazing Grace)

Go to <http://www.niehs.nih.gov/kids/lyrics/amazing.htm>

to hear the tune

The stars and stripes fly o'er my home,  
A land where all are free,  
The United States of America,  
The land of liberty.

I'm proud to be American,  
When I see our flag up high,  
Red, white and blue, the banner waves,  
Against the sunny sky.

**Point With Pride***Baltimore Area Council*

(Tune: Yankee Doodle)

Go to <http://www.niehs.nih.gov/kids/lyrics/yankee.htm> to

hear the tune

America is beautiful,  
With views beyond compare,  
So let's always stash our trash,  
And show her that we care.

Come on guys, let's do our part,  
And clean our countryside.  
And everywhere that we will go,  
We can point with pride!

Every litter bit hurts you,  
Remember this my friend.  
If you don't show us that you care,  
Where will our country end?

**Fly Your Flag***Baltimore Area Council*

(Tune: Row, Row, Row your Boat)

Fly, fly, fly your flag,  
On our holidays,  
Be a loyal citizen,  
In this and other ways.

**Flags of America***Catalina Council*

Tune: Yankee Doodle Dandy

We're the flags of America,  
We're as proud as we can be,  
Fifty flags of colors all so bright,  
Unitedly flying tonight.  
Representing peace and freedom,  
To all those who show respect,  
So when you see us flying high,  
Just stop and take a minute,  
To thank the mighty Lord above,  
For all that he has given.

**BANQUET TIME***Great Salt Lake Council*

Tune- On Top of Old Smoky

Our Blue and Gold banquets,  
The best in the town,  
We celebrate Scouting,  
While gulping food down,  
Cub Scouting's a pleasure,  
And eating is too!  
Do pass the fried chicken,  
Yea, the Gold and the Blue.

**STUNTS AND APPLAUSES****APPLAUSES & CHEERS****State Slogan Cheers***Jim Jones, Great Salt Lake Council*

☞ Print the State Slogan on the back of large outlines of the States.

☞ When a cheer is called for, have someone pick a state and lead the audience in the cheer on the back.

**See List in Theme Ideas***Sam Houston Area Council*

**The ABC Cheer.** Divide the group into three smaller groups. Assign to each group either "America," "Beautiful," or "Country." Point to different groups and have them yell out the word. Vary your speed.

*Baltimore Area Council*

**Fourth of July Cheer:** Stand up straight and shout "The rockets red glare!"

**Firecracker Cheer:** Strike a match on the leg, light the firecracker, make noise like fuse "sssss", then yell loudly "BANG!!"

*Catalina Council*

**Statue of Liberty** Stand and raise imaginary torch and say, "Welcome to America!"

**Mount Rushmore:** Chant in unison

Washington, Jefferson, Lincoln, Roosevelt

**America**

Spell America three times, then yell "Cub Scouts" twice, then yell USA – like so -

A-M-E-R-I-C-A, A-M-E-R-I-C-A, A-M-E-R-I-C-A; Cub Scouts, Cub Scouts, USA

**Abe Lincoln Cheer**

That was great! (short pause) HONEST!

**Constitution Cheer**

We the people, APPROVE!

**RUN-ONS****WASHINGTON'S FAREWELL ADDRESS***Great Salt Lake Council*

It is announced that a member of the pack has memorized Washington's Farewell Address and is about to do a dramatic portrayal of it. A boy emerges dressed as Washington and delivers his farewell address:

**Washington:** Bye, Mom!" (He exits the stage.)

*Catalina Council*

- Cub 1: Why aren't you doing very well in history?
- Cub 2: Because the teacher keeps asking about things that happened before I was born!
- Cub 1: Do you know the 20th President of the US?
- Cub 2: No, we were never introduced !
- Cub 1: Abraham Lincoln had a very hard childhood, he had to walk 7 miles to school everyday.
- Cub 2: Well he should have got up earlier and caught the school bus like everyone else !
- Cub 1: What did they do at the Boston Tea Party ?
- Cub 2: I don't know, I wasn't invited!
- Cub 1: How did you do in your tests ?
- Cub 2: I did what George Washington did !
- Cub 1: What was that ?
- Cub 2: Went down in history !
- Cub 1: Which amendment gives you the right to pull up your sleeves?
- Cub 2: I don't know.
- Cub 1: The Second Amendment – the right to bare arms.
- Cub 1: What did Paul Revere say when he got on his horse?
- Cub 2: Giddy up horsey !

*Great Salt Lake Council*

- Cub #1** What three states have the most cows?
- Cub #2** I don't know. Which ones?
- Cub #1** Cow-lorado, Moo-ssouri, and Cow-lifornia.
- Cub #1** What did they do at the Boston Tea Party?
- Cub #2** I don't know, I wasn't invited.

*Baltimore Area Council*

Two boys enter carrying another boy from a pole.  
 The emcee asks what they are doing.  
 The man hanging from the pole replies. "I'm just hanging around."  
 The two men supporting the pole respond by (gently) "dropping the subject" on the ground.  
 What is the difference between a Cub Scout going to the second floor of the Empire State Building and a Cub Scout looking up the stairs the Empire State Building?  
*One is stepping upstairs and the other is staring up steps.*

**Only in America**

*Alice, Golden Empire Council*

- Only in America.....  
can a pizza get to your house faster than an ambulance.
- Only in America.....  
do people order double cheese burgers, large fries, and a DIET Coke.
- Only in America.....  
do banks leave both doors to the vault open and then chain the pens to the counters.
- Only in America.....  
do we leave cars worth thousands of dollars in the driveway and put our useless junk in the garage.
- Only in America.....  
do we use answering machines to screen calls and then have

- call waiting so we won't miss a call from someone we didn't want to talk to in the first place.
- Only in America.....  
do we buy hot dogs in packages of ten and buns in packages of eight.
- Only in America.....  
do they have drive-up ATM machines with Braille lettering.

**JOKES & RIDDLES**

*Sam Houston Area Council*

- Cub #1:** What starts with T, is filled with T, and ends with T?
- Cub #2:** A teapot!
- Cub #1:** Do you know what's at the end of the road?
- Cub #2:** The letter D!
- Cub #1:** What is a lion's favorite state?
- Cub #2:** Maine!
- Cub #1:** What is an artist's favorite state?
- Cub #2:** COLOR-ado!
- Cub #1:** What body of water do you find between the Atlantic and Pacific oceans?
- Cub #2:** Tennes- SEA!

**Mayflower Run On**

*Alice, Golden Empire Council*

- Cub #1** My aunt is always late.
- Cub #2** Why is that?
- Cub #1** I guess it's because of her ancestors.
- Cub #2** What do her ancestors have to do with her being late?
- Cub #1** My dad says her ancestors arrived in America on the JUNE Flower!

**Always Safe? Run On**

*Alice, Golden Empire Council*

- Cub #1:** Why is an American astronaut like a football player?
- Cub #2:** I don't know. Why IS an American astronaut like a football player?
- Cub #1:** They both like to make safe touch-downs.

*Catalina Council*

- What did Delaware? She wore her New Jersey.
- What did Idaho? She hoed her Maryland.
- What did Tennessee? She saw what Arkansas.
- Which is the friendliest state? O-hi-o.
- What do people from Minneapolis call a small soda? A mini-soda.
- Where do cow go on vacation? Moo York.
- Who should you call when you find Chicago, Ill? Baltimore, MD.
- Can you name the capital of every state in the union in less than fifteen seconds? Yes, Washington, D.C.
- Which ex-U.S. presidents are not buried in the US? Carter, Bush, and Clinton.

Knock, knock Who's there? Abraham Lincoln. Abraham Lincoln who? Don't you know who he is?	Knock, knock Who's there? George Washington. George Washington who? You really don't know much, do you?
---	---

## SKITS

### Happy Birthday

*Sam Houston Area Council*

#### Setting –

Five Scouts are needed with one of them selected to be the “singing telegram.” This Scout needs to be sure to wear a hat with a small sign on it that says “singing telegram.”

#### Scene –

A table with a birthday cake on it that notes how old Scouting is. A bright table cloth and balloons can add color and atmosphere. The four Scouts are gathered around talking when the “singing telegram” Scout (S.T. below) enters, and starts to sing.

**S.T.:** Happy birthday to you! Happy birthday to you...

**Cub #1:** Hey! What are you doing? What’s going on?

**S.T.:** I’m delivering a singing telegram.

**Cub #2:** To whom?

**S.T.:** If you would listen to the end of my telegram, you’d find out. (starts to sing) Happy birthday to you! Happy birthday...

**Cub #3:** Excuse me – what’s going on?

**Cub #1:** He’s delivering a singing telegram to someone here, but he won’t tell us who.

**S.T.:** If you’d just be patient a little while longer, you’d find out. (starts to sing) Happy birthday to you!...

**Cub #4:** Hey! I heard singing. Who’s having a birthday?

**Cub #2:** He won’t tell us. He says we have to wait.

**Cub #3:** It’s not my birthday. Is it yours?

**Cub #4:** Not mine!

**Cub #1:** Not mine either!

**S.T.:** (exasperated) If you could just wait a moment, I’m almost done with the song. (starts to sing) Happy birthday to...

**Cub #3:** Come on, friend. Tell us who you’re singing for.

**Cub #2:** Yeah, we really want to know!

**Cub #4:** Are you sure he’s here tonight?

**S.T.:** All right! All right! I’ll tell you! (All Scouts gather round and whisper.)

*Now, all Scouts turn around and face the rest of the group and shout*

**ALL:** Happy Birthday Cub Scouting!

#### Radio Wanderer

*Sam Houston Area Council*

**Materials:** a chair, a table, and a big radio

**Setting –** As many Scouts as there are in a den. Adapt this skit by adding lines or taking away lines. One Scout sits in front with the radio. Be sure to practice this – timing is very important. The other Scouts are behind the stage with a microphone. They are the radio voices.

**Scene –** Cub Scout #1 enters, sits in the chair, and turns on the radio. He changes the station often.

**Cub #2:** Today in Houston, Texas it will be hot and humid with a high of 95 degrees and a 30% chance of rain. Boy, do we need the rain, so everyone be sure to carry your ...

*(Cub #1 changes radio station.)*

**Cub #3:** Alligators were seen again carefully crossing the streets in Destin, Florida yesterday afternoon, and while you

may be tempted to get close and take some pictures, folks, please be careful! Alligators are known for their big...

*(Cub #1 changes radio station.)*

**Cub #4:** Hands the ball to number 16 on the basketball team and he easily dribbles down the court for a basket! This team is hot, ladies and gentlemen. With the win today, they are on their way to Los Angeles, California for ...

*(Cub #1 changes radio station.)*

**Cub #5:** Ice Cream. Get your ice cream! Up here in Waterbury, Vermont at the Ben & Jerry’s factory, we are enjoying the tour of the world famous ice cream design studio. In fact, we’re about to get a chance to taste the newest flavor...

*(Cub #1 changes radio station.)*

**Cub #6:** Spongebob Squarepants is up next boys and girls and you won’t want to miss this episode. Right after a word from our sponsor, he and his buddy Patrick plan fun and adventure on a field trip to...

*(Cub #1 changes radio station.)*

**Cub #7:** The Mojave Desert in Arizona is the topic of our historical perspective this afternoon. Actually taking up parts of Arizona, Utah, Nevada, and Southern California, the Mojave Desert is named after the Mojave Native Americans, who occupy 51,000 square miles of this region. This desert will sometimes see snow in the winter, and many forms of wildlife like the...

*(Cub #1 changes radio station.)*

**Cub #8:** Cub Scouts of Pack \_\_\_\_ will be celebrating a Blue & Gold banquet this evening to highlight all the awesome achievements they have earned this past month. Cub Scouting is a great way to make new friends and try new activities. If you’re interested in joining, please call your local council office.

**Cub #1:** (Turns off the radio and turns to the audience and shrugs.) There are so many great shows on the radio – I can’t decide what to listen to.

#### See The USA

*Catalina Council*

**Personnel:** 6 Cubs Setting:

Boys asking questions could hold up a cardboard cutout in the shape of their states.

**All:** See the USA in your Chevrolet. America is asking you to call. (This is repeated between each of the questions.)

**Cub # 1:** I am known as the Garden State. People in my towns often work in factories. I was admitted to the Union in 1787. Who am I? (New Jersey)

**Cub # 2:** I am in the Northwest and am known as the Evergreen State. People in my towns might work in the lumber industry. They might even make airplanes or computer software. I was admitted to the Union in 1889. Who am I? (Washington)

**All:** See the USA in your Chevrolet. America is asking you to call.

**Cub # 3:** I am on the banks of the Mississippi River. People in my towns are sometimes farmers who grow corn. My capital is Des Moines. I was admitted to the Union in 1846. Who am I? (Iowa)

- All:** See the USA in your Chevrolet. America is asking you to call.
- Cub # 4:** I am the largest state in the United States. Most of my land is still wilderness. The people in my towns work in the fishing industry. I was admitted to the Union in 1958. Who am I? (Alaska)
- All:** See the USA in your Chevrolet. America is asking you to call.
- Cub # 5:** I am known as the beehive State. People in my towns work on farms and in business. I was admitted to the Union in 1896. Who am I? (Utah)
- All:** See the USA in your Chevrolet. America is asking you to call.
- Cub # 6:** I am located in the Southwest. Within my borders are high plains, majestic mountains, and dry deserts. I was admitted to the Union on Valentine's Day in 1912. Who am I? (Arizona)
- All:** See the USA in your Chevrolet. America is asking you to call.

### AMERICA THE BEAUTIFUL

*Great Salt Lake Council*

#### SET UP:

- Den Leader (DL) and 7 Cub Scouts
- Curtains on stage - behind which is U.S. Flag (Either a painting, or a print or a real flag opened out flat - blue in upper left corner).
- Artist's Smock for each Cub, large paint brush and paper palettes.

#### STORY:

- DL:** We are honored to have as our guests a group of famous artists, who are going to combine their efforts and talents to paint us a great masterpiece. As they are introduced they will tell you what their contributions will be.
- Cub # 1:** I will paint for you the tradition and charm of New England, showing you the fishing and boating industries of its rugged coast and its historic heritage. (Steps behind curtain.)
- Cub # 2:** I will portray through my brush the tremendous harbors of New York City; the melting pot of peoples from many lands that make up its teeming population. (Steps behind curtain.)
- Cub # 3:** My artistry will show you the charm of our Southland, the beauty of its magnolias and azaleas, the strength of its struggle through and after the Civil War years; and the contrast of the serenity of Kentucky's bluegrass country with old New Orleans at Mardi Gras time. (Steps behind curtain.)
- Cub # 4:** May I add to our canvas just a little of the beauty of our great Midwest; cosmopolitan Chicago; Detroit, the automobile capital of the world; the waving grain of the rolling plains; and the deep blue of the ten thousand lakes of Minnesota. (Steps behind curtain.)
- Cub # 5:** Our great South and Mid-west will be a task to portray, BUT no mere picture can convey the majesty of the Grand Canyon, the beauty of the

Painted Desert, the expansiveness of Texas or the splendor of the Colorado Rockies; the fantastic land of geysers, Yellowstone Park, or the Great Salt Lake in Utah. (Steps behind curtain.)

- Cub # 6:** Our beautiful West Coast reaches from the hot Mexican border to the cold snows of Alaska. In between, we find Hollywood's glamour, the Golden Gate Bridge of San Francisco, towering redwood, sequoia, and Douglas fir trees, the beauty of Oregon's Crater Lake, and majestic Mt. Rainier in Washington. Where once rough, tough gold prospectors were found in Alaska, now tourists spend happy summers experiencing, among other things, Denali and the wilderness of our largest state. (Steps behind curtain.)
- Cub # 7:** I will complete our picture with the waves of the famous Waikiki Beach, with Diamond Head volcano in the background of the exotic metropolis of Honolulu. Our newest State, Hawaii, with its blue waters and active volcanoes makes for a lush tropical paradise. (Steps behind curtain.)
- DL:** And now for the unveiling. May I present our great masterpiece!

*As the curtains are slowly parted and "America the Beautiful" is played, the flag is solemnly shown, with the "artists" standing on each side of the United States Flag they just "painted".*

### America

*Catalina Council*

**Characters:** 7 Cubs, 6 wearing costumes depicting themes related to the states. All seven carrying a letter spelling out **America**

#### **Cub # 1: Rhode Island:**

Small in size, large in heart,  
Freedom of worship gave us our start;  
One of the original thirteen,  
Home of Roger Williams and Nathaniel Greene;  
Many Americans daily are fed,  
By our state bird, the Rhode Island Red.

#### **Cub # 2: Mississippi:**

Look away, look away, Dixieland  
Many brave men at Tupelo and Vicksburg took their stand;  
Magnolias still bloom and mockingbirds still sing,  
But the Natchez Trace with voices no longer ring.

#### **Cub # 3: Colorado:**

First came the real mountain men,  
The trappers and traders  
Then gold seekers and railroaders;  
Finally coal miners gave way to skiers and oil,  
John Denver sought and Robert Redford still seeks to save our soil.

#### **Cub # 4: Idaho:**

The River of No Return halted Lewis & Clark temporarily,  
Traders, farmers and shepherders  
followed their trail merrily;  
Today, tourists gaze in awe  
at the wonders they saw,  
And even eat our famous potatoes raw!



**Cub # 5: Arizona:**

Navajo, Hopi, Apache,  
were led by Cochise and Geronimo;  
Our large Indian population  
continues to help us grow;  
Copper, cotton, cattle, citrus and climate are the "C's"  
That have proven to be economic key.

**Cub # 6: Alaska:**

North to Alaska was the cry,  
Gold fever was the reason why;  
Seward's Folly was no more,  
But it was 1959 before America officially opened its door;  
The Alcan highway was the first link,  
The pipeline added strength.

*(Boys look for the missing letter)*

**Cub # 7: "E": Isn't this neat?**

Without me there is no America.  
I represent Everyone,  
And that's what makes America complete  
*Boys line up in proper order AM\_RICA  
then E comes on last.*

## CLOSING CEREMONIES

### CLOSING CEREMONIES

#### American ABC'S Closing

*Sam Houston Area Council*

Sing the "Star-Spangled Banner"

Supplies – Make a map of the United States with the following listed cities highlighted

Introduction: "A tour of the USA by the letters."

The ceremony –

☞ Have everyone stand and sing the "Star-Spangled Banner"

☞ After the song, have Scouts read off a name from the list and point it out on the map.

*Do this alphabetically.*

*Assign boys multiple parts, if needed*

- Cub # 1:** Anchorage, Alaska
- Cub # 2:** Boston, Massachusetts
- Cub # 3:** Cherokee, Kansas
- Cub # 4:** Dover, Delaware
- Cub # 5:** Everglades, Florida
- Cub # 6:** Freedom, California
- Cub # 7:** Gallup, New Mexico
- Cub # 8:** Hartford, Connecticut
- Cub # 9:** Independence, Missouri
- Cub # 10:** Jefferson, Iowa
- Cub # 11:** Knoxville, Tennessee
- Cub # 12:** Lincoln, Nebraska
- Cub # 13:** Montgomery, Alabama
- Cub # 14:** Neptune, New Jersey
- Cub # 15:** Oshkosh, Wisconsin
- Cub # 16:** Providence, Rhode Island
- Cub # 17:** Quartzite, Arizona
- Cub # 18:** Revere, Minnesota
- Cub # 19:** Sleepy Hollow, Wyoming
- Cub # 20:** Tornado, West Virginia
- Cub # 21:** Ulysses, Pennsylvania
- Cub # 22:** Vermillion, South Dakota

**Cub # 23:** Washington, DC

**Cub # 24:** Xenia, Ohio

**Cub # 25:** Yakima, Washington

**Cub # 26:** Zapata, Texas

**CM** From A to Z, Scouts do exciting things all over our great land.

### Flag Closing

*Sam Houston Area Council*

**Setting** – color guard, Cubmaster (or 5 Cub Scouts, each reading one verse of the poem)

**Scene** – Cubmaster (or 5 Cub Scouts) reads the poem below as color guard slowly retires the flag.

**Cub # 1:** We watch the flag as it passes by  
A flash of color against the sky;  
Its fifty stars are a dazzling white  
As those few that shown by the dawn's first light.

**Cub # 2:** The brave, bright red that will never fade  
By the blood of men's sacrifice was made.  
The white, for our nation's purity  
Can be kept from stain by you and me.

**Cub # 3:** The blue, the vastness of God's own sky,  
His promise that freedom shall never die.  
The mighty cities, the farmlands fair,  
The many churches for praise and prayer.

**Cub # 4:** The chance to do and the chance to be  
In a land our forefathers fought to free.  
The hope that the world is looking for  
Our good will for peace but our strength for war.

**Cub # 5:** All these are the flag of our dear land  
A symbol we cherish and understand.  
As we bare our heads and our hearts beat high  
As our flag, "Old Glory" is passing by.

### Ideals

*Baltimore Area Council*

**Set Up:** Eight Cubs each with a placard with his phrase on front and his part in LARGE print n the back.

**Cub # 1:** DO YOUR BEST in everything you do on life's way.

**Cub # 2:** ALWAYS BE FRIENDLY to brighten other people's day.

**Cub # 3:** GIVE AWAY YOUR SMILES for 'tis rewarding indeed.

**Cub # 4:** BE PREPARED to help others in their daily need.

**Cub # 5:** BE HONEST AND SINCERE towards others you meet.

**Cub # 6:** BE LOYAL AND TRUE a most commendable feat.

**Cub # 7:** COUNT YOUR BLESSINGS, being thankful each day for life's opportunities that come your way.

**Cub # 8:** Good night to each and every one of you. May these thoughts stay with you your whole life through.

### Liberty

*Catalina Council*

**Personnel:** Narrator and seven Cub Scouts.

**Equipment:** Seven large card , each with a letter to form the word **Liberty**.

**Setting:** In order, each Cub Scout steps forward turning his card so that the letter maybe seen by the audience and recites the phrases given below.

**Narrator:** The word "Liberty" is held so dear. Each letter is a symbol of this nation held together by love, not fears. Man has fought and died in years gone by, but the meaning stays the same for you and I.

**Cub # 1: L:** L is for **Laws** made for the protection of all

**Cub # 2: I:** I is for **Ideals** who's standard shall not fall

**Cub # 3: B:** B is for **Bravery**, for all, not a few

**Cub # 4: E:** E is for **Equality** upheld through and through

**Cub # 5: R:** R is for **Religion**, a matter of choice

**Cub # 6: T:** T is for **Truth**, which we are free to voice.

**Cub # 7: Y:** Y is for **Youth** inspired from the start.

**All:** It's all up to you - so do your part!

### Americanism

*Catalina Council*

*Or maybe you would prefer this as an opening CD*

**Personnel:** 11 Cubs

**Equipment:** Card with part on the back and large capitol letters on front to spell out **Americanism**.

**Cub # 1: A is for Advantages**

We have so many more;  
Because we are American  
Let us give thanks therefore.

**Cub # 2: M Is For Majority**

Decision by the most;  
That's the rule we follow  
From coast to rugged coast.

**Cub # 3: E Is For Education**

Available to all;  
So every last American  
Stands up straight and tall.

**Cub # 4: R Is For Religion**

We worship as we will;  
A right we'll always cherish  
And let no evil kill.

**Cub # 5: I Is For Independence**

That our fathers once declared;  
Our nation rose to greatness  
Because these brave men dared.

**Cub # 6: C is for Citizenship**

Of which we can be proud;  
So let's proclaim it daily  
And do it long and loud.

**Cub # 7: A is for Assembly**

To gather as we might;  
That's another privilege  
Another previous right.

**Cub # 8: N Is For The News**

A press that's always free;  
A sentinel on watch  
To guard our liberty.

**Cub # 9: I is for Impartial**

Equal justice for us all;  
Law — the same for everyone  
The great, the poor, the small.

**Cub # 10: S Is For Our Speech**

Though others may disagree;

You may still express yourself

Because our speech is free,

**Cub # 11: M Is For Our Motto –**

And that is why we say,

"In God We Trust, To live

The good American way.

## Cubmaster's Minutes

### Do Your Best

*Sam Houston Area Council*

Every Cub Scout should accomplish something worthwhile each day. Each day's accomplishments should be a little better than the day before. Stand by a window with your room dark and look out into the night, and ask yourself this simple question: Have I done my best today? Then each day, vow to do better than the day before. If all of us do that, and keep our promises, we will have the best Cub Scout pack in the country. Before we close, I want to ask you a question. Answer it silently to yourselves. "Have you done your best today?"

### Remembering our X Y Zs

*Sam Houston Area Council*

At the start of our pack meeting this evening, we looked at the ABC's of Cub Scouting. You might say ABC's stands for All Boys Can and then you fill in the blank of what comes next. All Boys Can Succeed. All Boys Can Play. All Boys Can Achieve. These are wonderful aspirations for our Cub Scouts. There are other words, not so impressive, that we could have used to fill in those blanks. But that's not Scouting! In Cub Scouts, we participate in character connections and we discover fitness and citizenship qualities, and have a welcoming spirit that engages all the young men. As we end tonight, we've traveled through our alphabet following a most unique path, as one would expect from Cub Scouts. At the end of our path, we've found XYZ. Let us remember the XYZ's of Cub Scouting, too – X-ceptional Young men with a Zest for adventure.

### Freedom Closing Thought

*Baltimore Area Council*

Freedom is a breath of air,  
Pine-scented, or salty like the sea.  
Freedom is a field newly-plowed,  
With furrows of democracy.

Freedom is a forest,  
Trees tall and straight as men.  
Freedom is a printing press,  
The power of the pen.

Freedom is a country church,  
A cathedral's stately spire.  
Freedom is a spirit,  
That can set the heart on fire!

### Baden-Powell & Gilwell Island

*Great Salt Lake Council*

In 1907. Baden-Powell took 21 boys with him to Brownsea Island, off England's southern coast, for what was to be the world's first Scout camp. It was successful beyond his wildest dreams. Because of this beginning, Scouting was organized in America and in many other countries.

Today, there are more than 15 million Scouts and Scouters around the world. Time changes many things, but the aims of Scouting are the same today as when it started. Please stand, give the Cub Scout Sign, and say the Cub Scout Promise.

**THEME RELATED STUFF**

**State Abbreviations**

*Jim Jones, Great Salt Lake Council*

<u>State/Possession</u>	<u>Abbreviation</u>
ALABAMA	AL
ALASKA	AK
AMERICAN SAMOA	AS
ARIZONA	AZ
ARKANSAS	AR
CALIFORNIA	CA
COLORADO	CO
CONNECTICUT	CT
DELAWARE	DE
DISTRICT OF COLUMBIA	DC
FLORIDA	FL
GEORGIA	GA
GUAM	GU
HAWAII	HI
IDAHO	ID
ILLINOIS	IL
INDIANA	IN
IOWA	IA
KANSAS	KS
KENTUCKY	KY
LOUISIANA	LA
MAINE	ME
MARSHALL ISLANDS	MH
MARYLAND	MD
MASSACHUSETTS	MA
MICHIGAN	MI
MINNESOTA	MN
MISSISSIPPI	MS
MISSOURI	MO
MONTANA	MT
NEBRASKA	NE
NEVADA	NV
NEW HAMPSHIRE	NH
NEW JERSEY	NJ
NEW MEXICO	NM
NEW YORK	NY
NORTH CAROLINA	NC
NORTH DAKOTA	ND
NORTHERN MARIANA ISLANDS	MP
OHIO	OH
OKLAHOMA	OK
OREGON	OR
PALAU	PW
PENNSYLVANIA	PA
PUERTO RICO	PR
RHODE ISLAND	RI
SOUTH CAROLINA	SC
SOUTH DAKOTA	SD
TENNESSEE	TN

TEXAS	TX
UTAH	UT
VERMONT	VT
VIRGIN ISLANDS	VI
VIRGINIA	VA
WASHINGTON	WA
WEST VIRGINIA	WV
WISCONSIN	WI
WYOMING	WY

**State Slogans and Nicknames**

*Jim Jones, Great Salt Lake Council*

<u>State Slogan</u>	<u>Nickname</u>
AL Share the Wonder	Cotton State
AK Beyond Your Dreams, Within Your Reach	Last Frontier
AZ The Grand Canyon State	Grand Canyon State
AR The Natural State	Natural State
CA Golden State	Find Yourself Here
CO Enter a Higher State	Centennial State
CT Constitution State	Full of Surprises
DE First State	It's Good Being First
FL Sunshine State	Sunshine State
GA Georgia on My Mind	Peach State
HI The Islands of Aloha	Aloha State
ID Great Potatoes. Tasty Destinations.	Gem State
IL Right Here. Right Now.	Land of Lincoln
IA Life Changing	Hawkeye State
IN Restart Your Engines	Hoosier State
KS There's No Place Like Home	Sunflower State
KY Unbridled Spirit	Bluegrass State
LA Come as you are. Leave Different	Pelican State
ME Worth a Visit, Worth a Lifetime	Pine Tree State
MD Seize the Day Off	Old Line State
MA Make It Yours	Bay State
MI Pure Michigan	The Great Lakes State
MN Explore Minnesota	North Star State
MS Feels Like Coming Home	Magnolia State
MO Show Me State	Show-Me State
MT Big Sky Country	Treasure State
NE Possibilities ... Endless	Cornhusker State
NV Wide Open	Silver State
NH You're Going to Love it Here	Granite State
NJ Come See For Yourself	Garden State
NM Land of Enchantment	The Land of Enchantment
NY I Love New York	The Empire State
NC A Better Place to Be	Tar Heel State
ND Legendary	Peace Garden State
OH so Much to Discover	Buckeye State
OK Oklahoma is OK	Sooner State
OR We Love Dreamers	Beaver State
PA State of Independence	Keystone State
RI Unwind	Ocean State
SC Smiling Faces. Beautiful Places.	Tar Heel State
SD Great Faces. Great Places.	Artesian State
TN The Stage Is Set For You	Volunteer State
TX State of the Arts	Lone Star State
UT Life Elevated	Beehive State
VT Vermont naturally	Green Mountain State
VA Virginia is for Lovers	The Old Dominion
WA Say WA!	Evergreen State

WV	Open for business	Mountain State
WI	Stay Just a Little Bit Longer	America's Dairyland
WY	Like No Place on Earth	Equality State

**Trivia from Alabama to Wyoming.**

*Alice, Golden Empire Council*

Alabama is the only state with all major natural resources needed to make iron and steel. It is also the largest supplier of cast-iron and steel pipe products.

When a scale map of Alaska is superimposed on a map of the 48 lower states, Alaska extends from coast to coast. Alaska is over twice the size of Texas.

The original London Bridge was shipped stone-by-stone and reconstructed in Lake Havasu City, Arizona.

You can look for precious gems, including diamonds, amethyst, garnet, jasper, agate and quartz at Crater of Diamonds State Park in Arkansas.

The highest and lowest points in the continental United States are within 100 miles of one another in California. Mount Whitney measures 14,495 feet and Bad Water in Death Valley is 282 feet below sea level.

The 13th step of the state capital building in Denver, Colorado is exactly 1 mile high above sea level.

Connecticut is home to the first hamburger (1895), Polaroid camera (1934), helicopter (1939), color television (1948), and the first lollipop-making machine (1908).

The United States city with the highest rate of lightning strikes per capita is Clearwater, Florida.

Georgia was named for King George II of England, and is the nation's number one producer of peanuts, pecans and peaches.

Hawaii is the only state that grows coffee. There are only 12 letters in the Hawaiian alphabet.

In Idaho law forbids a citizen to give another citizen a box of candy that weighs more than 50 pounds.

The ice cream "sundae" was named in Evanston, Illinois. Town fathers passed an ordinance prohibiting the retailing of ice cream sodas on Sunday, so ingenious confectioners and drug store operators served ice cream Sundays, with the syrup of your choice without the soda. Objection was made to christening a dish after the Sabbath. So the spelling of "Sunday" was changed to sundae.

At the St. Louis World's Fair (Missouri) in 1904, Richard Blechyden, served tea with ice and invented iced tea. The ice cream cone was also invented at the 1904 Fair, when a vendor ran out of cups and rolled up waffles to hold ice cream.

The light bulb, phonograph (record player), motion picture projector were invented by Thomas Edison in his Menlo Park, **New Jersey** laboratory.

The Genesee River, New York State, is one of the few rivers in the world that flows south to north.

The King Ranch in Texas is bigger than the state of Rhode Island, and El Paso is closer to Needles, California than it is to Dallas.

Wyoming has the lowest population of all 50 United States, but was the first state to give women the right to vote.

Was your state left out? Want to know more trivia about a state? Go to [www.50states.com/facts/](http://www.50states.com/facts/) and click on any state

**TIGERS**

**FLAG FOLDING RELAY**

*Great Salt Lake Council*

Practice folding and unfolding a flag, relay style.

The first tiger and his partner unfold the flag,

The next Tiger and his partner fold it,

The next pair unfolds, etc.

As people arrive put them at the back of the line.

Teams who have done it can help guide the others.

**Patriotic Pinwheel**

*Catalina Council*

**Materials:**

2 pieces of construction paper  
*(the thicker the better)*

Scissors

Hole punch

Push-pin

Pencil with an eraser

Markers or crayons



**Directions**

- ★ Start by making two square pieces of paper. To make a square,
  1. Put the two pieces of paper together.
  2. Fold the corner of the pieces of paper over so the side (shorter) edge touches the longer edge
  3. Cut off the small rectangles (where the paper is still single thickness). The doubled pieces are now two squares (and each is folded into a triangle).
  4. Fold each triangle in half again.
  5. Unfold the paper.
- ★ Decorate one side of each sheet of paper.
- ★ Put the undecorated sides of the paper together.
- ★ Make four cuts along the fold lines - about halfway to the center.
- ★ Punch four holes in the pinwheel, one at each corner.
- ★ Gently gather each of the four points (with holes) to the center.  
*(Be careful not to crease the paper.)*
- ★ Push a push-pin through the four punched holes through the center of the pinwheel to attach the pinwheel to the side of a pencil's eraser.



**HAVE FUN WITH LETTERS***Great Salt Lake Council*

- ✓ Make block letters of each boy's name and have them decorate the letters with markers or other craft items.
- ✓ The letters can also be made out felt or fabric and sewn or glued with hot glue or tacky glue.
- ✓ The letters can also be stuffed with batting or fiber-fill.
- ✓ The boys can put them on their wall, or if it is fabric/felt they could be placed on their bed like pillows.

**PACK AND DEN ACTIVITIES***Catalina Council*

- ✓ Choose a city or an historical site to highlight.
- ✓ Invite a guest speaker who can share something special about the places your Cub Scouts have picked to discover.
- ✓ Search on-line for the places of interest in your town to get you started.
- ✓ Plan a field trip to a local museum or public library.
- ✓ Celebrate your blue and gold banquet with local foods from your choices of the ABCs and decorate to highlight your choice.
- ✓ This would be a good month to work on the Citizenship or Geography belt loop or pin.

**Den & Pack Activities***Alice, Golden Empire Council*

*Also, be sure to check out Alice's Advancement Ideas. She lists many fine projects and activities that are fun, creative and provide learning experiences in that section. CD*

- ✎ **Feature Folk Tales from different parts of the United States** and add foods from that area, a large map showing where each folk tale is based, games based on the characters or actions in the Folk Tale. For example, when focusing on Zorro, you could have boys "sword" fight with pool noodles. As a den, choose a different tale for each week, or as a Pack, have each den focus on a different Folk Tale.
- ✎ **Make a den or pack scrapbook featuring What Makes America Special** – this could include photos, poems or stories, pictures of scout or family visits to famous American scenes, information about things such as sports or foods that are unique to America or that were created in America
- ✎ **America's Heritage – A to Z** Have Pack families share their family's heritage – each family could bring a potluck dish, and artifacts or photos from their heritage. See if you can fill out every letter from A to Z in your pack – Australia to Zimbabwe??
- ✎ **Assign food for your Blue & Gold Potluck from A to Z.** (Last name starting with A-L brings Salad; L-R brings main dish; R-Z brings dessert)
- ✎ **Go through the Alphabet with activities at your den meetings during the month:** A=Advertise the Blue & Gold by making posters, B=Begin working on signing the National Anthem; C=Connect the Dots puzzle,

D=Do a short service project for your Chartered Organization, etc.

- ✎ **Decorate with scenic posters from across America** – Request from State Tourist bureaus online, check with a travel agent – these are often available at no charge on request! Another good source of beautiful posters is the Forestry Service.
- ✎ **Or decorate with flags from every state** – you can print them from online, or get blank ones online and let the boys color them in. Go to [www.infoplease.com/states.html](http://www.infoplease.com/states.html) to get state flags and profiles of each state. Also state mottos, geography.
- ✎ **Geo Map Quiz** – Collect old maps, use them on the tables as a center mat; cut out or block out the name and challenge each table to identify where their map is from – winning table gets first chance at desserts! (Check with AAA, stores that cater to recreational sports – they often have free maps available.)
- ✎ **Mount a large map of the United States and have everyone mark where they are from** – supply yarn and colored pins so each family can mark where family members have lived
- ✎ **Learn a new kind of ABC's - Learn to use sign language** to spell out your name, a special message about America. See boy's book or <http://www.cksinfo.com/signsymbols/signlanguage/american/index.html> free clipart of sign language, including baby signing
- ✎ **Invite a guest expert to teach the boys how to hand sign the National Anthem, or America the Beautiful** – then have the music playing in the background as the boys do the signing with their hands.
- ✎ **Celebrate Scout Week by doing a special service project in the community.** Be sure to wear uniforms or activity shirts if appropriate, and add your service hours to the National BSA service website.
- ✎ **Put up a display featuring Scouting in your community** – check with your local library, or ask a local retailer if you can put a display in their window. Be SURE to put up your display on time and take it down when scheduled!
- ✎ **Have a Window Display Contest in your community** – invite other packs to find windows in local businesses where they can show off Scouting. Invite local officials to judge the displays.
- ✎ **Participate in Scout Sunday or Sabbath** – boys and leaders can wear their uniforms, if appropriate in their religious venue. Some communities also host a special interdenominational Scout Sunday, or have a Scout Fireside on Sunday evening.

**Outdoor Ideas for Everyone***Oregon Trail Council***Tiger Cub**

Go outside and watch the weather (Achievement 5F).

**Wolf Cub Scouts**



Go fishing; in colder climates, go ice fishing (Electives 19b-c).

**Bear Cub Scouts**

Visit an historical place of interest in or near your town or city (Achievement 3d).

**Webelos Scouts**

Take a trip to a place that interests you by car, bus, boat, train, or airplane.

**State Quarter Neckerchief Slide**

*Sam Houston Area Council*

**Materials –**

Template of your home state,  
State quarter,  
Project foam,  
Scissors,  
PVC pipe (for back of slide),  
Hot glue gun

**Directions -**

1. Cut out the project foam. Use the scissors to cut out the design from the foam.  
*Alternatively, you could trace the state onto a piece of already cut out foam, and the slide is square/diamond/circle in shape with the drawn state on it.*
2. Hot glue the state quarter to the front of the foam piece.
3. Hot glue the PVC pipe piece to the back of the foam piece

**Optional -**

1. Trace the quarter onto the back of the state
2. Cut out the circle shape from the foam.
3. Insert the quarter into the hole in the foam (so the quarter is flush with the foam piece).
4. Glue a piece of foam across the back to anchor the quarter
5. Glue the PVC pipe onto the foam in the back of the state.

**Where Is It Found?**

*Sam Houston Area Council*



Using a map of your city, locate where you are having your den meetings. From there find and mark the following – the Court House, the police station nearest your home, a fire station near your home, the Public Libraries near your home, your school, local places of interest (bridges, parks, monuments, canals, rivers, lakes, stadiums, theatres). How about where your baseball team plays? Where did your den go on its last field trip? Try to figure out how far some of these landmarks are from where you are by adding up the miles noted on the map. How long would it take you to get there?

**Star Makers**

*Catalina Council*

- ★ Give everyone a piece of paper, about 5” square.
- ★ At the signal to go, each player rips the paper, trying to make a five-pointed star.
- ★ When 30 seconds are up, the judge calls “Time” and everyone has to stop whether he is finished or not.
- ★ The judge then inspects the stars, giving a prize to the person with the best star.

*For the instructions to do this with one scissor snip go to*

<http://www.ushistory.org/BETSY/flagstar.html>

*The trick is the 8 1/2" by 10" (not 11") paper*

**Romp Across America Obstacle Course**

*Catalina Council*

Construct an obstacle course with items to represent important things across America -

- ✓ **Statue of Liberty** – Each Scout is given a small amount of foil in order to make a liberty torch.
- ✓ **Go West Young Man** –Each Cub is given a pretend horse and runs a course that is marked by orange cones.
- ✓ **Crossing The Mississippi River** – Swimming pool filled with water has several rocks strategically set inside; the scout crosses the pool by stepping on the rocks.
- ✓ **Colorado Mines** – Large cardboard boxes set up in a maze and each Cub crawls through.
- ✓ **Gold Rush in California** – Swimming pool filled with sand; there just might be a chance of finding gold!
- ✓ **Logging In Washington** – Swimming pool with 2 x 4” board inside, symbolizing the logs. Cubs pretend to be loggers, as the walk on the logs.

**ABC Hike**

*Catalina Council*

Take a hike with your Cubs through your neighborhood, yard, or local park and ask them to try to find something that begins with a letter of the alphabet--A, B, C. This can played as teams as a scavenger hunt too. Remind your Cubs that working together as a team provides the best outcome.

**Flag Heart Tie Slide**

Catalina Council

**Materials:**

Wooden heart (2" at widest point)  
 Red, White & Blue Paint  
 Strip of suede or vinyl or PVC pipe  
 Hot Glue

**Directions**

- ℞ Base coat the heart with white paint.
- ℞ Then paint red stripes approximately 1/4 inch wide.
- ℞ Paint the left upper corner of the heart blue.
- ℞ Use the rounded tip of a paint brush to make the \*stars\* in the field of blue.
- ℞ Glue suede, vinyl or PVC pipe piece on back for loop for neckerchief.

**Macaroni Eagle**

Catalina Council

**Materials:**

Heavy cardboard  
 Shell macaroni & Spaghetti  
 White glue  
 Spray paint

**Directions**

- ✓ Draw eagle on heavy cardboard.
- ✓ Attach macaroni and straight spaghetti to cardboard with ordinary white glue. The bird's head is left bare except for shell macaroni beak and eye.
- ✓ Elbow macaroni forms the upper wings and body.
- ✓ Apply several layers to body area.
- ✓ Complete the wings with alternating rows of spaghetti and shell macaroni.
- ✓ Cover the tail with spaghetti.
- ✓ Add shell macaroni for talons.
- ✓ Spray paint as desired,

**Glove Windsock**

Catalina Council

*This looks complicated but I am sure our inventive Den Leaders can see lots of ways to simplify this.*  
*(e.g. iron on stars versus sewing)*

**Materials:**

- Two 1/2" silver jingle bells
- Jute twine
- Scissors
- Ruler
- Embroidery needle
- Glue gun and glue sticks
- Drill and drill bit,
- Paintbrush & stencil brush
- Beige garden glove w/ blue wrist band
- Acrylic paints: dark red, white & blue
- 15 - 1" wood stars, 3/16" thick\*
- (Optional: 15 - 1" white star buttons)
- 96" length of 5/8" navy blue ribbon
- 96" length of 5/8" white ribbon
- 48" length of 5/8" dark red ribbon
- Red crochet or heavy duty thread
- 1" letter stencil

**Directions**

1. Drill two holes in center of stars, approximately 1/4" apart.
  2. Paint stars white. Let dry. See photo.
  3. Paint fingers and thumb areas of glove dark red. Let dry.
  4. Stencil "U. S. A." on center top of glove, using navy blue to stencil letters and dark red to paint periods. Let dry.
  5. Sew ribbons and stars on glove.
  6. Cut navy blue and white ribbons in half.
  7. Fold each ribbon length in half. See photo.
  8. Place fold of one blue ribbon on front tip of little finger.
  9. Place star on top of ribbon fold and stitch in place with needle and thread, beginning at top of one hole and ending at top of other hole.
  10. Tie thread in a knot at top of star. Clip ends.
  11. Repeat same for remaining fingers and thumb alternating ribbon colors.
  12. Using photo as placement guide, sew five stars to front of glove band beginning at top of one hole and ending at top of another hole, tying threads in a knot at top of each star.
  13. Clip ends.
  14. Repeat same for remaining stars for back of glove band.
  15. Finish up. See photo.
- For hanging loop,**
16. Cut an 8" length from twine.
  17. Glue each end of twine to inside sides of top of glove.
  18. Cut two 5" lengths from thread
  19. Thread one bell to center of one thread, tying bell to one end of hanging loop in a bow.
  20. Repeat same for end of hanging loop.
  21. (Optional: Replace wood stars with buttons.)

**Pony Bead Flag**  
*Catalina Council*

**Materials:**

- Lanyard hook
- 31 Blue Pony Beads
- 38 Red Pony Beads
- 29 White Pony Beads

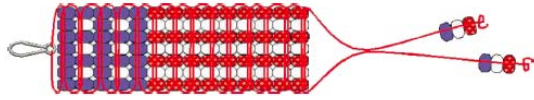

**Directions**

1. Fold your ribbon in half to find the center.
2. Use a half hitch to secure it to lanyard hook.
3. Lace beads using pattern above as guide.
4. Finish by tying off with a double knot.
5. Add beads on both ends.
6. Tie off and trim.

**American Flag Pin**  
*Great Salt Lake Council*

**What you'll need:**

- Coiless Safety Pin – 2 ¼"
- 4mm Round Beads
- "E" Beads
- Safety Pins, Size 2
- Pattern
- Long-Nose Pliers



**Directions:**

- ★ Each row hanging down is a size 2 pin with "E" beads strung on it.
- ★ Open these pins and string beads following the pattern shown. Keep in mind that you are stringing the beads upside-down so you will start at the top of each row and work down.
- ★ Then turn the pin upside down. Use pliers to squeeze the pin head closed permanently.

*Note: Glass beads are irregular in size. It may look like the pins will not close, but as long as the tip shows, you can usually just press the point into the pin head opening. The pin will bend out slightly to fit the beads snugly into place.*

- ★ Open up the coiless pin. You will need to bend it open to at least a 60 degree angle to get the beads on.
- ★ Beginning with the beaded pin to the far right, thread the coil of that beaded pin onto the coiless pin, around the bend and over to the head of the pin.
- ★ Slide on a 4 mm bead. Then the next beaded pin, followed by another 4 mm bead.

- ★ Continue until you have threaded on all pins and finished off with a final 4 mm bead.
- ★ These beads help hold the pins in place and keep them from sliding around the coiless pin.

**FUTURE PRESIDENTS**  
*Great Salt Lake Council*

**Materials:**

- Blank wall,
- Black construction paper,
- Pencil and
- Lamp/light to use as a spotlight,
- Scissors.

**Directions:**

- Have a boy sit in a chair or stand sideways to the wall about 1 foot away works well.
- Have the lamp about 1-2 feet away from the boy.
- Trace their silhouette on the black paper.
- Have each boy cut out his silhouette.

**Alternate Method** - If it is too hard to see the tracing on the black paper, then draw on white paper and put the black and white paper together to cut out black silhouette.

**HELPFUL HINTS**

*Great Salt Lake Council*

- ★ Put together a box with basic craft items. Some good craft items to have on hand are: foam sheets, stickers, felt, fabric scraps, scissors (both paper and fabric), pom poms, plastic canvas, empty egg cartons, empty cereal boxes, paper plates, brown paper bags (small and large), cookie cutters, plastic lids, glue (hot, white, tacky and stick), markers, crayons, colored pencils and tape (clear, masking, clear packing).
- ★ America is a nation of great variety. This month gives you an opportunity to learn about this nation with your Cubs Scouts. If your or your Cubs are planning vacations to other cities, find out about the city you or they will be visiting. Take the time to learn about the history of that city, including:
  - Sites and buildings and people associated with that history.
  - Try to learn about how the city got its name.
  - Find out about the ethnic groups that live in the city and the influence they have had on the city's culture.
  - You could learn about the geography of the region the city is located in, such as the rivers and streams, mountains, coastlines etc. and how these features affected the city's culture, economy and recreational activities.
  - You also might want to learn about the cultural activities of the city such music, dance, theaters, museums, historical and ethnic celebrations, and the amusement parks the people living there enjoy.
  - While you are at it, try to learn about the cities and towns you will be traveling through as well.
- ★ This can be an opportunity for a parent and or Cub leader to sit down with their cubs and learn about many

other cities in America as well. Whether the city is the one they live in. It is the city that their parents, grandparents or other relatives live in or the cities where their ancestors once lived in. There is much to learn about.

- ★ Other places to learn about might include the nation's capital, the various state's capitals, or even places that you might have heard about in the news.
- ★ You could learn about places associated with important historical figures, important battles associated with wars fought on American soil or other important historical events.
- ★ You may even try to learn about a city you would like to visit some day.
- ★ There are many resources you could turn to such as:
  - Libraries
  - Encyclopedias,
  - Atlases,
  - Almanacs
  - Tourist Information Centers
  - Auto Clubs,
  - Tourist Clubs,
  - Travel Agents
  - Genealogical Societies
  - Historical Societies
  - Cultural Associations
  - College Geography Departments
  - Foreign Embassies
  - Computer Programs And The Internet
- ★ This would be a good month to work on the citizenship, geography, and map and compass belt loops and pins and the Webelos traveler pin.

A website to go to for a good starting point on US History is: [www.historymania.com/american\\_history/List\\_of\\_U.S. Cities](http://www.historymania.com/american_history/List_of_U.S._Cities)

**Constitution Doorstop**  
Baltimore Area Council

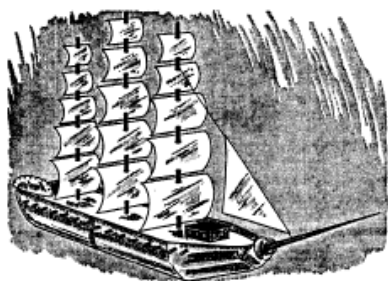

Every patriotic youngster will want one of these model ship doorstops for his room.

Our doorstop was inspired by the "Constitution," famed for her exploits in naval battles and affectionately nicknamed "Old Ironsides."

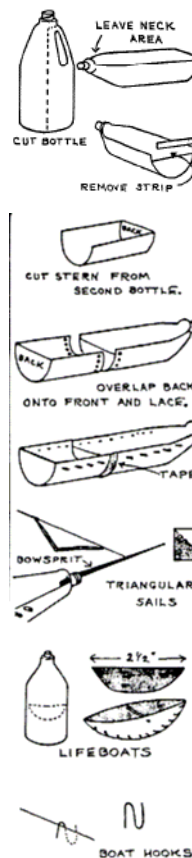

### Step #1 - The Hull

- The hull of the ship is made from two half-gallon plastic bleach bottles.
- Soak to remove labels and rinse thoroughly.
- Cut one bottle in half lengthwise, removing the handle completely, but leaving the bottle neck;
- Remove an additional 1/2" strip across bottom of bottle.
- Cut second bottle, as shown, for the stern end of hull.
- Cut several pairs of corresponding holes in both sections of hull.
- Overlap the two and tie together through holes, very securely.
- Seal by joining with tape on the outside.

### Step #2 - Guns

- For guns, insert matchsticks in holes punched along sides of the hull, about 1" from top.
- The "Constitution" had 44 guns.

### Step #3 - The Mast

- For the three masts, use 1/4" dowels, making one mast 15" long and the other two slightly shorter.
- Set masts in position in lumps of clay.

### Step #4 - The Bowsprit

- For the bowsprit, cut a 5" piece of a pencil or a dowel, tapering one end to a point.
- Insert bowsprit into the neck of the bottle and tape to hold.
- Paint masts and bowsprit.

### Next,

- Following directions on the package, mix a batch of plaster of Paris.
- Fill the hull to within 1/2" of the top, being sure to cover end of bowsprit and partition between the two sections of hull.
- When completely dry, paint hull and plaster deck.

### Step #5 - Cabins

- For cabins, glue on one or two small cardboard boxes.

### Step #6 - Sails

- From paper, cut five sails for longest mast, as follows: 4 1/2", 4", 3 1/2", 3", and 2 1/2" square. (Slightly smaller for other masts.)
- Punch a hole top and bottom of each sail.
- Now slide sails onto masts through holes, largest sail first, graduating sizes.



- Push paper sails down gently, so that each curves outward, as if blown by the wind.
- Attach a triangular sail to the bowsprit.
- Cut a 5" square of paper, fold in half diagonally,
- Take a length of string and run through fold, leaving extra string at each end.
- Paste sail together with string inside. Tie sail to bowsprit and to forward mast.

**Step #7 - Anchors**

- Cut anchors from the sides of plastic bottles.
- Attach to ship with string through holes cut in bow of ship.

**Step #8 - Lifeboats**

- For lifeboats, cut 1/2" x 1 1/2" pieces from curved side of plastic bottles to correspond to lengthwise curve of boat.
- Overcast pieces together with needle and double thread.
- Insert matchstick pieces for seats.
- Use fine wire to form hooks, as shown, to suspend lifeboats on side of hull.

## ADVANCEMENT IDEAS

From Program Helps via  
[www.cubroundtable.com](http://www.cubroundtable.com)

*If you follow the grid on the inside of the cover in the front of Cub Scout Program Helps, your Cub Scouts can complete earning their Rank Awards (Tiger, Wolf, Bear) by the Blue and Gold in February.*

*The suggestions in the Cub Scout Program Helps stop in January because of you have followed them, your Cubs have earned their badge of rank for the year.*

*Alice, Golden Empire Council*

Boys at all levels could work on the **Citizenship, Communicating or Geography Belt Loops**. This would also be a great time to work on special local or regional patches that focus on community and history. If your pack is having their Blue & Gold Dinner this month, be sure to have the Cubs do some of the decorations or other preparations as part of their advancement. Each den could be in charge of centerpieces for their tables, or prepare a game, skit or performance to be done at the dinner.

**Tiger Cub Achievements**

- Ach. #1F** – Make an American food favorite, such as the Cub Grub recipes, then help clean up;
- Ach. #1D** – Make and start adding recipes to a cookbook of family favorites; **Ach. #1G** – visit a library or local historical site to learn more about your community.
- Ach. #2** – Do any of the activities to learn more about your American community and how to be a good citizen;
- Ach. #3G** – Learn about a sport played in America, such as baseball or basketball, then go see a game
- Ach. #4G** - Visit a television or radio station or local newspaper to learn how communications are handled – take information about your den or pack, especially if you are participating in special Scout Week activities

**Tiger Cub Electives**

- Elect. #6** – Learn and sing a song for your Blue & Gold or pack meeting

**Elect. #8** – Get to know religious leaders; ask if you can have a special Scout Sunday or Sabbath

**Elect. #10, #11** – Honor the tradition of good deeds in Scouting by doing individual service to someone who needs a hand, or participate in a den or pack service project to help the needy

**Elect. #12** – Visit a long-term care facility and sing a scout song or do some scout activities; you could also ask if anyone was a scout themselves, and find out what they did as a scout

**Elect. #17** – make a Pinewood Derby model

**Elect. #20** – get the word out about Tiger Cubs

**Elect. #41** – Explore how Americans get around on buses, trains, planes or boats in your community

**Elect. #42** – Visit a zoo or aquarium in your community – look for American ABC animals

**Elect. #48**- Go for a ride on a bus or train – look for things that are special about America

**Elect. #49** – Visit a local government office to find out how American government works in your community

**Wolf Achievements**

**Ach. #1a, j** – Practice skills used in sports that originated in America

**Ach. #2** – Do any or all of the activities to show your patriotism; learn about your state and its flag

**Ach. #4f** – Visit an important place in your community and explain its importance

**Ach. #10c**- Go on a walk to a park, wooded area, or to visit a museum with your family – look for things unique to America; **Ach. #10d** – read a book about America or a Boy's Life magazine with your family; **Ach. #10e, f** – Watch television or listen to a radio show with Akela, or attend a concert or play with your family; **Ach. #10g** – Have a Family Board Game Night with your family – see if you can find games that were created in America

**Ach. #11d** – Find out how you can help your religious community; give service in uniform if appropriate

**Wolf Electives**

**Elect. #1c** – Learn another American alphabet – American Sign language.

**Elect. #2** – help plan and put on a skit about America or Scouting in America

**Elect. #4f** – Play a wide area or large group game with your den or pack – try one from Baloo

**Elect. #5g, h, i** – Make a pinewood derby model

**Elect. #9a** – help with a den party to celebrate the birthday of Cub Scouting in America

**Elect. #11** – learn to sing a song or songs; sing a grace at the Blue & Gold or a song at the pack meeting

**Elect. #12d** – help draw and paint scenery for a skit, play or puppet show; **Elect. #12e** – make a stencil pattern for a poster or sign; **Elect. #12f** – make a poster to advertise the Blue & Gold or Pinewood Derby



**Elect. #13a** - Make a list of birds you see in a week; **Elect. #13c** – read a book about birds, and find out where they live in America; **Elect. #13d** – Point out 10 different birds (try to focus on American birds)

**Elect. #20d** – know and practice safety rules for skiers; **Elect. #20e** – know and practice ice skating safety rules; **Elect. #20g** – go bowling, follow the rules and practice skills; **Elect. #20m** – show basketball skills and play a game

### Bear Achievements

**Ach. #3** – complete any or all of the activities to learn and demonstrate what makes America special

**Ach. #4** – Find out all about American folk tales, do any or all of the activities, share what you learn with your family, den or pack

**Ach. #5a** – Choose an American animal to learn about and make a poster; **Ach. #5c, d, e** – explain what a wildlife conservation officer does; visit a nature center in your area; learn about extinct animals

**Ach. #6g** – do a neighborhood clean up with your den or pack to demonstrate how scouting serves the community

**Ach. #8** – do any or all of the activities, as part of the Anniversary month of Scouting;

**Ach. #9b, f** – with an adult, make den snacks or a family dessert – try one from Cub Grub

**Ach. #10b** – Have a family fun night at home and play games that were created in America

**Ach. #11b** – learn what to do in case of an accident on ice

**Ach. #15b, c** – play games with your den. Give some from this packet a try!

**Ach. #17a** – watch a TV show with your family; **Ach. #17c** - visit a newspaper, TV or radio station and find out how stories are communicated; share information about Scouting and how you are celebrating this month; **Ach. #17d** – use a computer to find information about America or Scouting, then write a report to share.

**Ach. #18d** – Write an invitation to a den, pack or special Scouting event; **Ach. #18e** - write a thank you note to someone who has helped your den or pack celebrate Scouting Week or special activities. **Ach. #18f, g** – write about some thing you have done with your family, den or pack, especially any Scout Week activities

**Ach. #21a, b** – Make a Pinewood Derby car and a stand and/or a display for it

**Ach. #23** – Do any or all of the activities, and focus on American sports

### Bear Electives

**Elect. #3** – Do any or all of the activities; try to find out how radios connect different parts of the United States

**Elect. #17** – Do any or all of the suggested activities to demonstrate that scouts are helpful and learn useful skills

**Elect. #20b, c** – know safety rules and demonstrate skills for skiing and ice skating; **Elect. #20f** – earn a new Cub Scout Sports pin, repeat up to three times with different sports to earn arrow points

**Elect. #22a, b** – start a stamp collection and mount and display a collection of any kind you have made at a pack meeting; **Elect. #22c** – start your own library and organize a record keeping system

**Elect. #23a,b,c,d,e** – Use maps and do the activities to become more familiar with your community and country

### Webelos Activity Pins

**Scholar** You might focus on American education systems

**Engineer** – You might focus on engineering structures in America – for example, the Brooklyn Bridge or Golden Gate Bridge have fascinating stories and showcased innovative technology and engineering

**Citizen** – work on the requirements would fit with the theme of American ABC's

**Communicator #7, #8** – visit a newspaper, radio or TV station and find out how they receive information; furnish information about special Scout activities during February; write an article about Scouting for your local school or community paper; **#9, #10** – Invite a person to visit your den who uses another “American alphabet” – sign language or other means of communication for those with special needs or who speak another language.

**Family Member #8** – plan a night of family fun using games developed in America

**Forester, Geologist, Naturalist** – you might focus on plants, animals and rocks that are native to your area or to America

## GAMES

### State Nickname Charades

*Jim Jones, Great Salt Lake Council*

Put a few of State Nicknames from you area, or some of the easier to act out in a container and have someone draw them out and try to act them out as the audience tries to guess what the Nickname is and what State it is from.

Pick the States you use carefully as some State Nicknames will be more difficult to do than others.

*See List in Theme Ideas*

### ABC Memory Game

*Catalina Council*

*This is a good one for parents and siblings, too.*

**Materials:** None Directions:

**A:** One person starts the game by saying: “As I was traveling through the woods, I placed an apple in my bag. (or anything that begins with the letter A).

**B:** The next player names the A item and adds something starting with B - For example - “As I was traveling through the woods, I placed an apple and a balloon in my bag.”

**C:** Each additional player must repeat what was named and add to it something from the next letter of the alphabet.

*Mistakes make it funny!*

**ABC Name Game***Catalina Council**Another good one for parents and siblings, too.***Materials:** None **Directions:**

- A:** One person starts the game by saying a name for him (or her, if a sibling or Mom), a spouse's name, a place and a product that begin with A. For example: "My name is **Alex**. My spouse's name is **Anna**. We come from **Austin** and we sell **apples**."
- B:** The next player gives B names, places and things. For example - "My name is **Barbara**. My spouse's name is **Brian**. We come from **Boston** and we sell **beans**."
- C:** One more - "My name is **Christopher**. My spouse's name is **Christine**. We come from **Christmas Valley (Oregon)** and we sell **Christmas Trees**."
- D:** Proceed through the group, the next player just makes up names, place, and item for next letter.

*This game does not build. Not a memory challenge!***Travelers***Sam Houston Area Council*

- ☞ The leader tells the Cub Scouts that they are going on an imaginary trip.
- ☞ Each Scout can go anywhere he wants in the United States, but he must only use words that start with the first letter of the name of the place he is going to describe what he is going to do there.

**For Example -**

The leader asks the first Scout – "Where are you going?"

He might answer "San Diego."

The leader asks him – "What are you going to do there?"

He could reply, "Sing songs" or "slurp sundaes."

Answers can be very general.

- Going to the "country" to "chase cars" for example.
- Or, going to the "beach" to "bake biscuits."

**Geography***Catalina Council*

Divide into teams.

One team picks out a place on a U.S. map, calls out the name and challenges the other team to find it in four minutes.

If the other team gets it in the time limit, they get one point.

If they do not, the other team get the point.

The game ends when one team has earned 5 points.

**Texas Rodeo!***Sam Houston Area Council*

As each Scout arrives at the pack meeting, give him a sign with his number on it. Assign numbers at random as boys arrive. Signs could be made from cake cardboard or cut up cardboard boxes or poster board.

Set up booths around the "arena" for the Scouts to visit and earn points.

- Activities could include
  - Lassoing,
  - Horse shoe throws,
  - Balloon pop, etc...
 (*See How-To Book for more ideas*)
- Scouts could bring horses made from broom handles and paper mache, or an all wood design.

- Have barrel races with 5-gallon buckets as barrels.
- Scouts with the greatest number of points could compete in a rooster crowing contest (or all Scouts could "crow" as part of a chorus.)

**Minuteman Run***Catalina Council*

- The players form a circle and hold hands.
- A person who is chosen 'It' stands inside the circle.
- He walks around the circle, tapping each player's hands as he says each word of the rhyme, "Red, white, blue, out goes you!"
- The two persons he taps on the word, "You", run around the circle in opposite directions.
- 'It' steps into one of the empty places.
- The last one to get back to the empty place becomes 'It'.

**Ring the Liberty Bell***Catalina Council***Equipment:** Bell, Wire coat hanger, Heavy cord or rope, Small rubber ball.**Directions:**

- Bend the coat hanger into a hoop, with the hook at the top.
- Hang the bell in the middle of the hoop with the rope, and then tie the hoop from a low tree branch.
- This game may be played by individuals or teams.
- The players take turns trying to throw the ball through the hoop.
- Have a person stand on the other side of the hoop to catch the ball.
- Keep score as points are made.
  - Each time the bell is rung, the player scores three points.
  - If the ball goes through the hoop but doesn't touch the bell, he scores two points.
  - If the ball hits the outside of the coat hanger, the player scores one point.
- Each player throws the ball only once per turn, and gets five turns.
- After everyone is finished, add up the number of points scored by individuals or teams.

**We Fought Hard For Those 50 Stars***Catalina Council*

- Divide the group into equal teams, lined up a few feet away from the table.
  - Place a bowl on the table for each team.
  - Lay 50 cutout paper stars (approx. 2 inches in diameter) out on the table besides each bowl.
  - Give each player his own straw.
  - On the signal, the first player on each team, runs forward and picks up one or more stars, with one breath, by sucking on the straw.
  - He carries the star to the bowl and drops it in.
- NO HANDS.**
- He then tags the next person in line who does the same thing and the first person goes to the end of the line.
  - The first team to have all 50 stars in the bowl is the winner. (*Game can be varied to use 13 stars for a smaller group*).

**A National Tour***Sam Houston Area Council*

- ✓ Scouts sit in a circle with one Scout outside the circle. He is the tour leader.
- ✓ Each of the Scouts in the circle is given the name of a city in the United States (Austin, Baton Rouge, Carlsbad, Destin, Trenton, etc...).
- ✓ The tour leader walks around the circle and announces the next stop on the national tour.
- ✓ When a city is called (in any order), the Scout associated with that city gets up and starts following the tour leader.
- ✓ The tour leader may call as many cities, or as few, as he wants.
- ✓ When he calls 'BUS STOP AHEAD,' all the Scouts/cities rush back to the circle and sit down.
- ✓ The tour leader also tries to find a spot in the circle.
- ✓ The Scout left standing is the next tour leader.

**Map Reading Relay***Sam Houston Area Council*

- ★ Divide the den into two teams.
- ★ On tables across the room/space, place maps of the United States (or your state) and a marker/pencil.
- ★ Give each Scout on the team a city to find on the map (same cities for each team).
- ★ On signal, the first Scout from each team runs to his team's map and circles his city.
- ★ When he returns (leaving the marker/pencil at the map), he tags the next Scout who runs to the map and circles his city.
- ★ The relay continues until each Scout on the team has found a spot on the map and returned to the starting point.
- ★ The team who finishes the relay first wins.

**Drawing Columbus' Ship***Sam Houston Area Council*

- A pencil or marker and a piece of paper is all that is needed.
- The first player draws a line.
- He passes the pen to the next player, but keeps the pen on the paper at all times.
- Everyone has a turn, each trying to add the lines to drawing Columbus' ship.
- Having a picture available of Columbus' ship might help.

**Variation:** Draw the Statue of Liberty or something famous near you.

**Heave, Ho, Throw! Relay***Catalina Council*

*You should shorten these distances for Cub Scouts CD*

- Divide the group into two teams.
- Take one boy from each team about 20 feet from the rest of the group and have him sit in a designated spot.
- During the game, he may lean forward slightly and reach, but he cannot move from the spot.
- Give the first Scout in each line coil a rope about 25 feet in length.
- Each boy makes one throw, holding onto the end.

- The sitting Cub Scout tries to reach the rope being thrown without moving from his spot.
- Each boy in the relay line will throw the rope once, and then go to the end of the line.
- Teams score whenever the sitting boy can reach the rope thrown to him.
- One point is given for each throw that the sitting boy catches.
- The team with the most points is the winner.

**Eskimo Relay***Catalina Council*

**Object:** The team which is able to take the longest time to get the ice cube to the end of the line.

**Material:**

- 2 teams of 5 or 6 players,
- 3 adult judges and
- 2 to 4 ice cubes

**How to Play:**

- ✓ Place each team in line with the players standing behind each other about 3 feet apart.
- ✓ Give the 1st player in each line a large ice cube.
- ✓ At the signal, the 1st player turns and places the ice cube on the neck of the next player, who must stoop over.
- ✓ The 2nd player tries to balance the ice cube as long as he can.
- ✓ As soon as it slips he must either catch it or pick it up, then turn immediately and place it on the neck of the next person.
- ✓ This continues until the ice cube has gone all the way to the end of the line.
- ✓ The judges are on hand to ensure that no one dawdles.
- ✓ The use of hands is strictly forbidden except to move the ice cube from one person to the next.

**Here in America***Sam Houston Area Council*

- ✓ Scouts sit in a large circle.
- ✓ The first Scout gives the name of an American city, state, town, body of water, mountain or island.
- ✓ The next Scout must use the last letter of the word given by the previous Scout as the first letter of his American location.  
*For example, if the first Scout says "Houston," the second Scout could say "Nebraska," and the third Scout could say "Appalachian Mountains," etc...*
- ✓ This continues until a Scout repeats another Scout's word or cannot give a location in 15 seconds.
- ✓ The game continues with the next Scout.
- ✓ The last Scout to remain is the winner.

**Potato Wheel-barrow Race***Baltimore Area Council*

- ✓ Organize a wheel-barrow race with a team of two children--one on the floor walking on hands and the other holding up his/her feet
- ✓ Put a potato on the back of each 'wheel barrow'.
- ✓ Listen to the shrieks of glee!
- ✓ If the spud falls off, the team must return to the starting line.

**American Alphabet Shuffle***Sam Houston Area Council*

- Write each letter of the alphabet on a small index card.
- Place in the middle of a table and shuffle the cards.
- Divide the Scouts into 2 or 3 teams, depending on how large the group is.
- As the leader selects a card and shows it, the Scouts try to be the first on their team to name an American city that begins with the chosen letter (ex. A = Austin, Albuquerque).
- The first Scout to answer wins a point for his group.
- The team to reach a designated number of points first wins.

**Patriotic Colors***Baltimore Area Council***Equipment:** None**Formation:** Circle**Directions:**

- ✓ The leader sits in the middle of the circle, points to a player and calls 'red'.
- ✓ The player has to name an object that is red (e.g. tomato, fire engine) before the leader can count to 10 out loud.
- ✓ The same object cannot be repeated.
- ✓ If a player fails to think of an object before the leader has counted to ten, the two switch places.
- ✓ Use the patriotic colors 'red', 'white' and 'blue'.

**Tug Of Peace***Baltimore Area Council*

- ✎ A group of boys sit in a circle holding onto a rope placed inside the circle in front of their feet.
- ✎ The ends of the rope are tied together to make a huge loop.
- ✎ If everyone pulls at the same time, the entire group should be able to come to a standing position.
- ✎ The Tug of Peace can also be played by stretching the rope out straight and having boys sit on either side of it, facing each other in two lines.
- ✎ If both sides pull on the rope evenly, they can help each other up.

**Sorry You Missed***Baltimore Area Council*

- ★ Have the boys stand in a small circle while each in turn tries to toss a beanbag into a small container in the center.
- ★ If he misses he must drop out.
- ★ Each time around the boys move back a step.
- ★ Last one left wins the game.

**Independence Tag***Catalina Council*

'It' pursues the rest of the players and tries to touch one of them. When one has been touched, he must keep his hand on the spot where he was touched and pursue the others. His hand can not be freed from this spot until he has tagged someone else. The idea is to tag people in inconvenient places ... on the ankle, knee, etc.

**Destination Center***Sam Houston Area Council***Materials –**

One piece of stretchy elastic (like a BIG rubber band) tied in a circle, and  
A bucket for each team.

**Directions –**

- ✓ Divide Scouts into teams.
- ✓ The team must stretch out the elastic circle and release it in such a way that it falls into the bucket.
- ✓ Each Scout must hold the elastic with two fingers (one from each hand) and the team backs away from a bucket placed at the center of their group.
- ✓ The Scouts must keep the elastic fully stretched just before the release, and they must let go of the elastic at the same time. (So, one Scout cannot throw the elastic into the bucket...)

**American Foods Bingo***Alice, Golden Empire Council*

Go to [www.print-bingo.com](http://www.print-bingo.com) and print out Bingo cards with food categories such as Appetizer, Meat, Seafood, Fruit, Vegetable, Snack, Dessert, Camping, Potato in the squares. Each person or family gets a card and they have to fill in an American food that fits the category in each box. If you want to make it more interesting, start with foods beginning with "A," then add a food beginning with "B" and finally "C" in each square before they yell "Bingo!" (The winning card will have three foods in each square, one each beginning with A, B, and C)

**Famous American ABC Bingo***Alice, Golden Empire Council*

Follow the steps listed above, but either use blank squares that must be filled with famous American names, or use categories such as Author, Patriot, President, Sports Figure, Inventor, Founding Father, Astronaut, etc.

**CUB GRUB****Blue & Gold Shish-Ka-Bobs***Sam Houston Area Council***Ingredients –**

Bananas,  
Blueberries,  
Toothpicks

**Directions –**

- ✓ Slice bananas.
- ✓ Alternately place blueberries and bananas on the toothpick for a blue and gold treat.

**Blue & Gold Trail Mix***Sam Houston Area Council***Ingredients –**

Dried bananas,  
Blue m&m's (can be found in single solid colors at party stores),  
Coconut (if desired),  
Peanuts,  
Sandwich baggies or storage baggies

**Directions –**

- ✓ Give each Cub Scout a baggie.
- ✓ Place bananas, m&m's, coconut, and peanuts in individual bowls with spoons or scoops.
- ✓ Scouts spoon into their baggies an amount of each ingredient,
- ✓ Close the baggie, and
- ✓ Shake to mix.
- ✓ Enjoy!

**American ABC Pretzels**

*Alice, Golden Empire Council*

*Here's an easy recipe for pretzels that Cubs can make, since they don't have to be put in boiling water. The twist is that the boys form their pretzels into letters to fit our theme!*

**Prep time:** about 30 minutes

**Ingredients:**

- 1 tbsp. Yeast
- 1/2 c c. warm water
- 1/2 c. warm water
- 1 tsp. honey
- 1 1/3 c. flour
- 1 tsp. salt

**Directions:**

- ✓ Preheat the oven to 325 degrees Fahrenheit (165 degrees Celsius).
- ✓ Put the yeast in a small bowl with the water and honey.
- ✓ Stir a little, then let the mixture sit for 5 minutes.
- ✓ Mix the flour and salt together in a medium-size bowl.
- ✓ After the 5 minutes is up, check on the yeast mixture. It should be bigger than before and a little bubbly.
- ✓ Add this mixture to the flour and salt mixture.
- ✓ Stir everything together. Use a spoon to start. Finish with your hands. The dough is ready when it's still a little crumbly and flaky.
- ✓ Put the dough on a cutting board covered with flour and knead it like you are playing with clay.
- ✓ Knead it into one big ball.
- ✓ Break off a piece of dough that's about the size of a big gumball or superball.
- ✓ Use your hands to roll it into a skinny snake.
- ✓ Twist the snake into the shape of a letter and put it on a cookie sheet sprayed with nonstick spray.
- ✓ Do this with all the dough, making 12 pretzels.
- ✓ Bake your pretzels for 10 minutes.
- ✓ Let them cool and take a bite!
- ✓ **Makes 12 pretzels**

**Easy American Peanut Brittle**

*Alice, Golden Empire Council*

*Here's an American favorite,  
made extra easy by using the microwave!*

**Ingredients:**

- 1 1/2 cups unsalted peanuts
- 1 cup sugar
- 1/2 cup corn syrup
- 1 tsp. Vanilla
- 1 tsp. Butter
- 1 tsp. baking soda

**Directions:**

- ✓ Combine peanuts, sugar and corn syrup in microwaveable bowl.
- ✓ Microwave on high for four (4) minutes.
- ✓ Remove and stir.
- ✓ Microwave for three (3) more minutes.
- ✓ Remove from microwave and add vanilla and butter
- ✓ Stir. Then Microwave for 2 more minutes.
- ✓ Remove, add baking soda.
- ✓ Stir. Spread onto oiled cookie sheet or pizza pan.
- ✓ Cool until set.
- ✓ Break into pieces and enjoy!

**Fire Crackers**

*Great Salt Lake Council*

**Ingredients**

- 1 (6oz) can frozen grape juice, thawed
- 4 c lemon-lime soda
- 1 pint vanilla ice cream

**Directions**

- Pour concentrate into a pitcher and
- Gently stir in soda.
- Put two scoops ice cream into each glass.
- Pour grape juice over ice cream.
- Serve immediately.

**Oven-Baked Fries**

*Great Salt Lake Council*

**Ingredients**

- 4 medium sized potatoes
- 1 tbsp oil
- 1/4 tsp paprika
- 1/4 tsp salt

**Directions**

- ✓ Slice the potatoes into 1/2 inch fries.
- ✓ Toss in a bowl with oil, paprika, and salt until coated.
- ✓ Spread on a cookie sheet and bake 35 minutes at 475 °,
- ✓ Turn occasionally.
- ✓ Finish by sliding under the broiler for 1-2 minutes to brown.
- ✓ Makes 4 servings

**Firecrackers**

*Great Salt Lake Council*

**Ingredients**

- 5 cups coconut red food coloring
- 24 baked cupcakes cooled
- Blue decorating gel
- 1 tub (12 oz) nondairy whipped topping, thawed
- Red string licorice

**Directions**

- ✓ Tint coconut using red food coloring,
- ✓ Trim any "lips" off top edge of cupcakes.
- ✓ Using small amounts of whipped topping, attach bottoms of 2 cupcakes together.
- ✓ Repeat with remaining cupcakes.
- ✓ Stand attached cupcakes on 1 end on serving plate.
- ✓ Frost with remaining whipped topping.
- ✓ Press coconut onto sides; draw a star on top of each firecracker with decorating gel.
- ✓ Insert pieces of licorice for fuses.
- ✓ Store cakes in refrigerator. Makes 12



**Cub Scout Spoon Fudge***Baltimore Area Council***Ingredients**

- 1 lb. confectioners sugar
- ¼ lb. (1 stick) margarine or butter, softened
- 3-4 oz cream cheese, softened
- ½ cup baking cocoa (more or less, to taste)
- 1 tsp. Vanilla

**Directions**

Place all ingredients in a one gallon zip-lock plastic bag and seal securely. (This step is important; if you don't seal the bag securely you will have a big mess!)

Knead, pinch, squeeze and squish contents until it gets to a smooth, even texture (about 15 minutes).

Form into a ball and dump onto a plate.

Grab a spoon and dig in.

Fun for the whole den (serves 8-10 hungry Cub Scouts).

If sometimes you feel like a nut, add ½ cup or broken walnuts or pecans.

You can also add mini marshmallows or raisins.

**Uncle Sam Hats***Great Salt Lake Council***Ingredients**

- 1 package (18 oz) refrigerated chocolate chip cookie dough
- 2 c powdered sugar
- 2-4 tbsp milk
- Red and blue food colors

**Directions**

- ★ Preheat oven to 350 °.
- ★ Lightly grease 12 inch round pizza pan and baking sheet.
- ★ Remove dough from wrapper.
- ★ Press dough evenly into prepared pizza pan.
- ★ Cut dough into hat shape.
- ★ Use scraps from hat and a 1 ½ -2 inch star cookie cutter to cut out several stars;
- ★ Remove and discard remaining dough scraps.
- ★ Place stars on baking sheet.
- ★ Bake stars 5-7 minutes and hat 7-10 minutes or until lightly browned at edges.
- ★ Cool stars on baking sheet 1 minute.
- ★ Remove stars to wire rack; cool completely.
- ★ Cool hat completely in pan on rack.
- ★ Combine powdered sugar and enough milk, one tablespoon at a time, to make medium-thick pour able glaze.
- ★ Spread small amount of glaze over stars and place on waxed paper;
- ★ Let stand until glaze is set.
- ★ Using red and blue food colors,
  - tint ½ of glaze red,
  - tint ¼ of glaze blue and
  - leave remaining ¼ of glaze white.
- ★ Decorate hat with red, white and blue glazes;
- ★ Place stars on hat.
- ★ Let stand until glaze is set.

**WEBELOS****Webelos Resident Camp***It is not too early to think about this!!!*

Webelos Resident Camp is many things -- the sounds of boys laughter doing fun events and activities. Resident Camp involves the type of programs that can be hands on for the boys. Programs are designed for a Webelos Scout and a parent (or other adult) to spend time together and enjoy a few days of camping.

The purpose of Webelos Scout Resident Camping is to have fun and to instill in the Webelos a desire to want to continue to camp. Webelos Resident Camp is typically for boys going into grades four (This year's Bears) and five (This year's Webelos 1's) next fall. These Scouts will be your first and second year Webelos Scouts next fall. Webelos Resident Camps generally offer a wide variety of activity badges. Some work on a two-year cycle.

Webelos Resident Camp can include: camping, campfires, swimming, cookout meals, archery, bb-guns (*Starting in 2009 BSA says Webelos can use Pellet Guns!!*), hikes, ecology study, geology, star study, Scout's Own religious service, sports games and much more. The boys are kept busy and have a great time. (Especially in Southern NJ Council!! We have Cub-Anapolis Races, Water Bottle Rockets, Conservation, Movie Night, Root Beer Floats, Retro Day (50's & 60's or whatever), Hooked on Hockey presentations. They build their own camp stool and cook their lunches almost every day!!

*Find out about your council's Webelos Resident Camp!!  
And be there, this summer!!*



## SCHOLAR MENTAL SKILLS GROUP

### Den Activities

#### *Circle Ten Council*

- Let the boys talk about what's going on in school. Don't try to change any of their ideas, but guide the discussion in such a way that they will see the value of an education.
- Learn about the history of education, how schools developed in America.
- Prepare a chart of the school system and explain and discuss with boys.
- Discuss & do a den service project for the school.
- Invite the parents of Webelos to come to a den meeting dressed in the type of clothes they wore to school. Have them bring along such things as class pictures, yearbooks, report cards, etc. and allow each ample time to share his/ her school days with the den.
- Have a panel of parents with various jobs explain their schooling and training for these jobs.
- Invite an educator to talk with the den about some of the scholar requirements.
- As a den, talk about good study habits.
- Have someone from the public library talk about the local literacy project.
- Tour a local high school or visit a local college campus.
- Play a Newspaper Search game looking for articles about education.
- Encourage boys to find out all they can about schools in your community ... the different types and how they work... the problems and opportunities. Discuss these at a den meeting. Have the boys make a list of the things they like about school and another list of the things they don't like about school. Give these lists to the principal.
- Have the boys make a daily time schedule and use it to determine if they are making the best use of their time.

### Careers in Education

#### *Circle Ten Council*

Have each boy choose one career in education and think of what may be involved in that career. Have them make a collage of pictures that relate his ideas about that career. You may be surprised at a Webelos Scout's perception of some of these jobs. When done, discuss them and clarify any misconceptions.

### Speakers

#### *Circle Ten Council*

Teacher  
College professor  
School principal  
Librarian

### Additional ideas:

#### *Circle Ten Council*

Invite a member of the school board or a professional educator (teacher or principal) to talk to the boys on the value of an education and what school has to offer a boy.

Have the boys try to find out some of these things:

- What jobs are there at school for the boys to do?
- What extra-curricular activities are available?
- What community activities is the school used for?
- Who are the people on the office staff, cafeteria staff, and custodial staff? What are their responsibilities?
- What are some of the problems of the school, and how can you help?

Have the boys list what they consider the best and worst things in their school. Arrange to give these lists to the principal or a school board member. Invite them to a den meeting to talk with the boys. Important to the participants in such a meeting is a feeling of trust and comradely. Allow the meeting to have an informal setting. After respectfully introducing the guest, let it become an informal rap session. A few cookies and punch served by the Denner has worked wonders in the past. Now is the opportunity for the leader to blend into the woodwork and enjoy observing. Do not become concerned with a lack of participation on the boys' part. If the guest is someone concerned with the boys of this age group, he or she will draw them in. A little more informal would be a meeting at school between the boy and a teacher. Have the boy list questions and set up approximately 10 minutes to meet. Have the boy discuss his meeting at a den meeting.

### Field Trips

#### *Circle Ten Council*

Plan a trip to the library to have the librarian demonstrate the use of a microfilm or microfiche viewer.

Ask a librarian to explain the Dewey Decimal System or Library of Congress system, visit the public library, and have boys complete applications for library cards, if they do not already have one.

Briefly visit a school board meeting. Let them know you are coming. They may be interested to know the boys are working on the Scholar Activities Badge.

### Spelling Mixer

#### *Circle Ten Council*

Print large letters on 5x8 index cards, one letter per card. Do not use the letters J, K, Q, V, X or Z. Make several cards with vowels on them. Have a card for each person in the group. On signal, the Cubs hold up their cards, then rush around to find two other people with letters that when combined with theirs, makes a valid 3-letter word. They must lock arms, in order and rush to a judge who writes their word on the back of their card if the word is valid. Then they separate and each rushes to find two more letters to make another word. Play continues for 5 or 10 minutes. The winner is the person with the most words on his or her card.

2035

*Circle Ten Council*

Have the boys discuss what they think school will be like 25 years from now. Will the students all be at computers? Will they interact with teachers from a TV hookup from their homes? Will they travel to Mars for math and Saturn for science? Will someone have invented a smart pill for every subject? In the future, will we do away with some of the subjects that are taught now? Which ones? What new subjects might be offered? Divide them into groups to make posters of their view of education in the future.

**Seven Ways to Improve Grades***Circle Ten Council*

**Learn to Listen** - Look at the speaker, concentrate on his words, take notes, participate in discussions.

**Develop Good Study Habits** - Avoid distractions, have supplies handy, do homework at the same time each day, make a list, do the things you hate first, schedule a short break if needed.

**Use the Right Reading Technique** - learn to skim by glancing through whole paragraphs at a time; use slower, more careful reading when you must understand and remember.

**Improve Your Vocabulary** - look up words you don't know, write them down, use the word(s) in your next conversation.

**Sharpen Your Writing Skills** - brainstorm for ideas, organize your thoughts, keep sentences short, use neat handwriting, double check spelling and punctuation.

**Learn How to Take Tests** - study well ahead of time (don't cram), relax, then face the test; read the directions carefully; answers questions you know for sure, pace yourself, work steadily; go back and fill in missing answers as best you can; double check your work for careless errors and omissions.

**Develop a Positive Attitude** - you are what you think you are - use positive thinking!

**History of American Education***Circle Ten Council*

Each of the paragraphs below contains information about education during four different periods of American history. Discuss what America was like during each period, then, as a den, read each and decide which period the information most probably reflects:

Colonial	America during 1600 – 1775
Early 19 <sup>th</sup>	America during 1775 - 1865
Late 19 <sup>th</sup>	America during 1865 – 1915
20 <sup>th</sup> Century	America from 1915 until today

1. Education reflected and participated in the development of "The American Way." American History was instituted in schools during this time period. Education became more secular in nature, and states enacted laws requiring compulsory school attendance.
2. Resources were limited and physical demands left little room for education. Education was initially established for religious motives (Puritans in New England.) Most education of this period was either in the home or apprentice training. Nine colleges were formed during this time period.

3. Enrollments in elementary and secondary schools were above 90% of the eligible students. Wide inequities developed between states and local school districts. America's schools have developed as the nation has advanced.
4. As the population became more concerned with technology and material progress, education progressed in turn. Education was influenced by European immigrants and travel to Europe. Secondary education replaced the academy and public high school became a reality.
5. Three practices of education were established during this time: 1) Compulsory education, 2) Public support of schooling, and 3) Three levels of education (elementary, secondary, and higher) were set up.
6. This was the beginning of a movement toward state school systems. Establishment of the elementary level was completed. Secondary education was taken care of through academy training. Numerous new colleges were started in the early nineteenth century.
7. Colleges increased their courses and programs. Teaching grew more toward a profession and teachers became concerned with a methodology of education.
8. School efforts have been structured towards quality education; while the size of the education system increased in size greatly. In schools the vocational education program diversified its offerings, while general education was considered a preparation for earning a living. Schools began to look more toward the students vocational pursuits.

(Answers: 1-Early 19<sup>th</sup>, 2-Colonial, 3-20<sup>th</sup> Century, 4-Late 19<sup>th</sup>, 5-Colonial, 6-Early 19<sup>th</sup>, 7-Late 19<sup>th</sup>, 8-20<sup>th</sup> Century)

**Can You Follow Directions Test?***Circle Ten Council*

***This is a classic that I remember from my school days. I hope you can have some fun with it. CD***

This test is to see if you can follow directions. Concentrate, but remember, you have only two minutes to complete this. Read everything before doing anything.

1. Put your name in the upper right-hand corner of this paper.
2. Circle the word "name" in sentence number 2.
3. Draw five small squares in the upper left-hand corner of this paper.
4. Put an "x" in each square.
5. Put a circle around each square.
6. Put a circle around each word in sentence number 5.
7. Put an "x" in the lower left-hand corner of this paper.
8. Draw a triangle around the "x" you just put down.
9. If you think you have followed directions up to this point, call out "I have."
10. Now that you have finished reading this carefully, do only number 1 and number 2.

You have finished. How did you do?

**Study Skills**  
*Circle Ten Council*

You are the captain of your very own scholar-ship (learning). Teachers and parents can help, but how well you do in school depends greatly on how well you do your homework. School has just started. Imagine that your scholar-ship has just left port for a nine-month cruise. You will decide how smooth the trip is going to be. You will set your goals and chart your own course. Before your scholar-ship really gets under way, it's a good idea to check your skills to find out where you need to improve. You'll want to get your scholar-ship into shipshape. Draw a face that would show how well you think you use your study skills.

**Lifestyle** - Do you allow enough time for sleep, rest and fun activities?

**Assignment** - Do you keep up with and write down your assignments?

**Schedule** - Do you set aside time to study?

**Place** - Do you have a good, quiet place to study?

**Organization** - Do you organize your study area?

**Focus** - Do you keep your mind from wandering by remembering your study skills?

**Review** - Do you ask yourself questions or have your parents ask you questions to make certain you understand what you have studied?

**ENGINEER  
TECHNOLOGY GROUP**

**Mouse Trap Powered Catapult**  
*Norm*

**Materials**

- Mouse trap
- 3/4" thick pine board - stop block, bottom and arm
- 1/2" (or 5/8") plywood for sides
- 1/4" plywood for trigger
- 1 1/2" screws
- 10d to 16d nails ("d" means penny size for nails)
- Bottle cap

**Directions**

Assemble per drawing

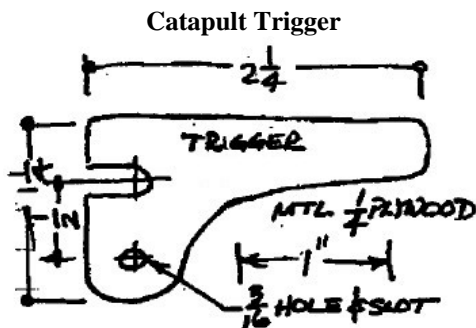

**Mouse Trap Catapult**

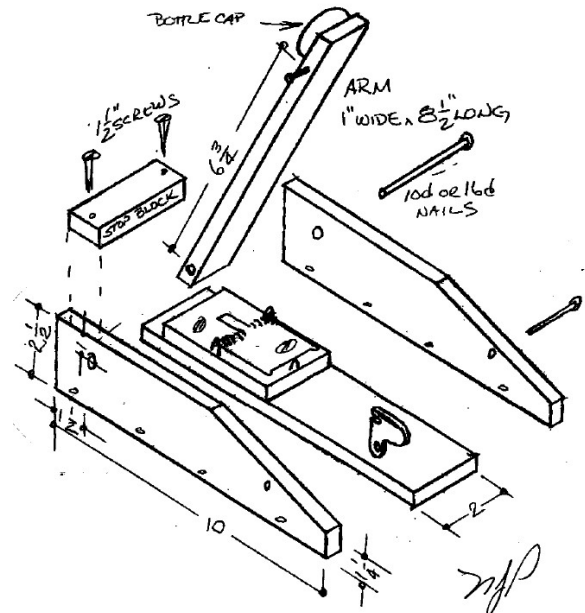

*Baloo's Archives*

One of the great things about being a Webelos Leader is the opportunity to learn many things along with the boys. Unless you are an engineer, there may be some knowledge to pick up with this activity badge to pass on to your boys. Recruit the help of a parent who is an engineer.

One of the purposes of Cub Scouting is "fostering a sense of personal achievement by developing new interests and skills" in boys. This activity badge probably does this more than any of the other badges. Engineering is one of the most exacting of the professions and the badge includes projects that will give a boy an insight into some types of engineering.

**Den Activities:**

Arrange for boys to visit an engineer or surveyor in a municipal county office. Plan for the boys to look through the surveyor's manual and read a rod. Visit a construction site and see the plans which are being followed.

*We visited the new Ranger's House while it was under construction out at our Scout Camp. Everyone was very eager to show it off to us. Make sure you get permission before visiting any construction site. CD*

- Visit the County water works, TV or radio station.
- Have someone explain how to read topographic maps.
- Have a builder or carpenter show and explain a floor plan of a house.
- Make a block and tackle. Be sure to explain its purpose.
- Make catapults and demonstrate them at pack meeting, shooting candies or marshmallows into the audience for distance.
- Discuss property lines. Have a surveyor show how property lines are determined and measured.
- Discuss different types of engineers. If one can visit your den, let him describe briefly what his duties are.
- Have boys collect pictures of bridges and note the differences in construction.

Take a field trip to an operating draw bridge (ex. St Croix River), ship loading operation or other large industrial operation involving large cranes or other lifting equipment.

### **Fields Of Engineering**

*Aeronautical Engineering:* Deals with the whole field of design, manufacture, maintenance, testing, and the use of aircraft both for civilian and military purposes.

*Astronautical Engineering:* Closely related to aeronautics, but is concerned with the flight of vehicles in space, beyond the earth's atmosphere, and includes the study and development of rocket engines, artificial satellites, and spacecraft for the exploration of outer space.

*Chemical Engineering:* Concerned with the design, construction, and management of factories in which the essential processes consist of chemical reactions.

*Civil Engineering:* Perhaps the broadest of the engineering fields; deals with the creation, improvement, and protection of the communal environment; providing facilities for living, industry, and transportation, including large buildings, roads, bridges, canals, railroad lines, airports, harbors, and other constructions.

*Electrical Engineering/Computer Science:* Divided broadly into the engineering of electrical power distribution systems, electrical machinery, and communication, information, and control systems.

*Geological & Mining Engineering:* Includes activities related to the discovery and exploration of mineral deposits and the financing, construction, development, operation, recovery, processing, purification, and marketing of crude minerals and mineral products.

*Industrial or Management Engineering:* Pertains to the efficient use of machinery, labor, and raw materials in industrial production.

*Mechanical Engineering:* Broadly speaking, covers the design and operation of all types of machinery and small structures.

*Safety Engineering:* Concerned with the prevention of accidents.

*Sanitary Engineering:* A branch of civil engineering that has acquired the importance of a specialized field due to its great importance for a healthy environment, especially in dense urban population areas.

### **Some Engineering Functions**

*Research:* A search for new scientific knowledge, with the objective of applying it to solving problems.

*Development:* Applied research which results in working model.

*Design:* Conversion of developed ideas into economical, reliable, and producible plans of manufacture, use or construction.

*Maintenance:* Plan and direct the methods of making the design and transforming it into a useful product.

*Sales:* Define and explain the application of the product and the sale of it.

*Management:* Administrate any or all of the engineers which perform the functions listed above and any other personnel required to perform the assigned task.

### **Field Trips**

*Adapted from Heart of America Council*

- 1) Visit (with permission) a housing project or a commercial building construction site, possibly in conjunction with a visit by an engineer as a guest speaker at your meeting.
- 2) There are many big engineering structures around our country – dams, bridges, towers, sewerage plants, buildings, stadiums, power plants ... Many times you can get an inside tour of these structures that would fascinate your Webelos. However, I am not sure how many have stopped (Like the Delaware Memorial Bridge near me) after September 11. Many times there are even visitor centers near the structures explaining how they were built. I never tire of seeing Hoover Dam constructed in 22 minutes on the screen in the museum in town. The Corps of Engineers office at Clinton Lake, west of Lawrence, Kansas, has a display on the building of the dam at the lake and how a dam works. Maybe you could combine some of these trips with a fishing trip or nature hike at the lake made by the dam or a nearby state park.

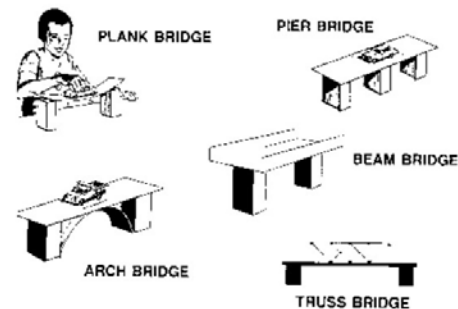

- 3) Bridge Tour:

*Heart of America Council had a route for seeing various types of bridges in their area. I am sure with a little work and a few phone calls you could come up with an itinerary for a bridge tour in and around your town. CD*

For an idea the HOAC Route was -

- a) From the Heart of America bridge (Locust going north over the Missouri River), to the east you can see a classical suspension bridge carrying I-35. Also known as the Paseo bridge.
- b) West from the Heart of America bridge you can see two truss bridges of different design and then the Broadway bridge which is a suspension bridge suspended from arched girders.
- c) Further west, an arch bridge goes over 7th Street just north of I-35.
- d) The 12th Street bridge over the Kaw River is especially interesting. The first span as you proceed north is a plank bridge, the next three spans are classical cantilever, and the last is truss.
- e) Any number of pier type bridges can be seen in the area. The majority of the bridges used in the Interstate systems are of this type. Be sure to notice that while the bridges are pier type, the piers themselves are sometimes cantilevered from side to side across the roadway.



In my area we have  
 Classical suspension – Delaware Memorial, Walt Whitman,  
 Ben Franklin, George Washington

*The very first modern suspension bridge in the US is the  
 Williamsburg Bridge in New York city. It was 100 years old on  
 December 19, 2003!! CD*

Cantilever – Delaware Route 1 over the C&D Canal,  
 Commodore Barry Brige  
 Arch – I-95 over the Brandywine River  
 Steel Arch – Bayonne Bridge

In a 5 mile section of Delaware SR 1 between Smyrna and  
 Dover in Kent County, Delaware, there are seven bridges.  
 Two bridges are dual, single-span steel beam bridges. Three  
 bridges are two-span, steel girder bridges. The remaining  
 two bridges are dual, multi-span, pre-stressed concrete girder  
 bridges.

I am sure, the more you look at the bridges around your area,  
 the more you'll realize that there are few pure one-type bridges.  
 Most are bridges that incorporate several design types in one.  
 For instance, many pier type bridges over the railroad tracks are  
 arched to provide strength while conserving materials.

**Show How Electricity Comes to Our House**  
*Circle Ten Council*

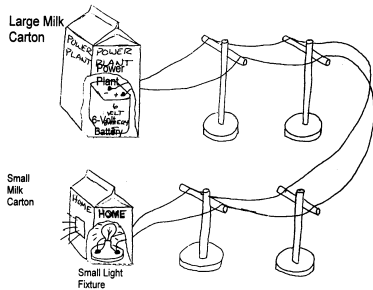

Make a small scale electrical system

Equipment:

- 6 Volt Battery
- Wooden Dowels
- Insulated wire
- 2 - Milk Cartons
- Small Light fixture

**Model Elevator**  
*Circle Ten Council*

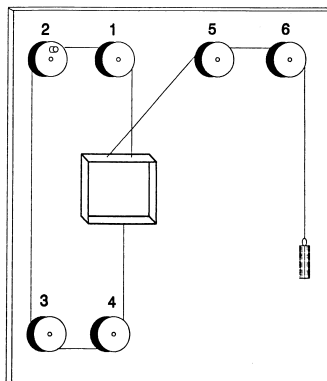

Nail Thread spools loosely to board, sip string over 1,2,3 and  
 4. Wind string several times around 2. Wind second string  
 over 5 and 6 and attach weight for balance. Turn handle on 2  
 to move car up and down.

**POW WOW  
 EXTRAVAGANZAS**

*Let me know as soon as your date is set. I will post  
 whatever I receive! CD*

**Southern NJ Council  
 Cub Scout Centennial Express**

January 24, 2009  
 Lakeview School, Millville, NJ 08332  
 Call Southern NJ Council, 856-327-1700, extension 32, or  
 visit the website, [www.snjscouting.org](http://www.snjscouting.org) for more information  
**And on-line registration!!!! No paper!!!**

**WEB SITES**

*Great Salt Lake Council*

A website to go to for a good starting point on US History is:  
[www.historymania.com/american\\_history/List\\_of\\_U.S.\\_Cities](http://www.historymania.com/american_history/List_of_U.S._Cities)

*Alice, Golden Empire Council*

- [www.factmonster.com/ipka/A0770175.html](http://www.factmonster.com/ipka/A0770175.html)
- More on Fifty States and Fifty Fun Facts from Fact Monster;  
 census games; kid's center
- [www.enchantedlearning.com/usa/states/](http://www.enchantedlearning.com/usa/states/)  
 State maps, symbols, links to related quizzes
- [www.50states.com/facts/](http://www.50states.com/facts/)  
 Trivia about any state
- [www.infoplease.com/ipa/A0801718.html](http://www.infoplease.com/ipa/A0801718.html)  
 Flags from every state, includes a list of state mottos
- <http://www.cksinfo.com/signssymbols/signlanguage/american/index.html> Learn how to use American sign language –  
 another kind of American ABC's – sign a favorite song or  
 poem, or learn how to sign your name
- [www.infoplease.com/ipa/A0801718.html](http://www.infoplease.com/ipa/A0801718.html)  
 has a list of all state mottos
- [www.surfnetkids.com/games/American\\_Games/](http://www.surfnetkids.com/games/American_Games/)  
 great site with printable flags, interactive American Flag  
 games, games about US Geography, government, holidays  
 and history and biographies of famous Americans
- [www.doverpublications.com](http://www.doverpublications.com)  
 sign up for free coloring pages you receive by email
- [www.kidsgeo.com/geography-games/united-states-america-map-game.php](http://www.kidsgeo.com/geography-games/united-states-america-map-game.php)  
 interactive games, your choice of history, geography, etc.

## TWO ~~ONE~~ LAST THINGS

To achieve your dreams, remember your ABCs

York-Adams Area Council

- A - Avoid negative sources, people, things, and habits.
- B - Believe in yourself.
- C - Consider things from every angle.
- D - Don't give up and don't give in.
- E - Enjoy life today: yesterday is gone and tomorrow may never come.
- F - Family and friends are hidden treasures. Seek them and enjoy their riches.
- G - Give more than you planned to give.
- H - Hang on to your dreams.
- I - Ignore those who try to discourage you.
- J - Just do it!
- K - Keep on trying, no matter how hard it seems. It will get better.
- L - Love yourself first and foremost.
- M - Make it happen.
- N - Never lie, cheat, or steal. Always strike a fair deal.
- O - Open your eyes and see things as they really are.
- P - Practice makes perfect.
- Q - Quitters never win and winners never quit.
- R - Read, study and learn about everything important in your life.
- S - Stop procrastinating.
- T - Take control of your own destiny.
- U - Understand yourself in order to better understand others.
- V - Visualize it. Want it more than anything.
- X - Xccelerate your efforts.
- Y - You are unique of all of nature's creations. Nothing can replace you.
- Z - Zero in on your target, and go for it!

### A Boys' Life Rap

Uncle Miltie, Golden Empire Council

Reading Time: 3 minutes.

Tempo: 4/4, upbeat, like, you know, RAP.

*This is "Uncle Miltie's" great Boy's Life Rap - He is the Commissioner of all Commissioners in Golden Empire Council. He presented this at the Commissioner's Conference. Hilarious to see this guy who is even older than me put his cap on backwards, get us going with the rhythm and sound effects, and then do this Rap! It would be a great way to encourage everyone to get Boy's Life.*

Alice

*Boys' Life* is more than just something to read –  
It really gives boys what they want and need.  
Since 1911, it's been coming through  
With super ideas that are always new.

It's full of stories on things boys like,  
Like eatin', and cookin', and hikin' on a bike,  
Adventure, hobbies, sci-fi, and sports,  
People, and places, and fun of all sorts,  
Plus: the very best features that can be found,  
Like video games and "Scouting around,"  
"Bible Heroes" and "Scouts in Action,"  
To add to the reader's satisfaction.

Scouts who hate homework (even though they might need it)  
Will pick up *Boys' Life*, and continue to read it  
From cover to cover -- and even miss dinner --  
'Cause they know what's there will make them a winner.

Kids don't give a hoot that this magazine  
Has won lots of prizes for being so keen;  
They don't want to build up "good reading habits;"  
They just want to know about snakes, and rabbits,  
Campsites, web-sites, and lots of other things,  
Like the NFL. and the Sacramento Kings.

Take it from Pedro, the *Boys' Life* burro:  
You can make your impact even more thorough,  
'Cause it does the thing that you can't do –  
*Boys' Life* keeps goin' after you're all through!  
It delivers the program of the B. S. A.,  
Reinforcing Scouting every hour of the day!

You'll never regret the time you spent  
To help each unit be "100 Percent."  
Don't let 'em get by, be very persistent --  
Sign 'em up for *Boys' Life*, your "silent assistant."

The best packs and troops, and varsity teams  
All take *Boys' Life* (or so it seems),  
And each subscription helps them toward  
A National Quality Unit Award!

Here's more good news you'll like to hear --  
They get it half-price, just a few bucks a year.  
That's a super bargain, for a deal so nice.  
("The Gear Guy" alone is worth the price!)

Here's another point, 'fore we end this rap –  
*Boys' Life* helps close the "Generation Gap."  
It does it with humor, in the "Think And Grin" pages;  
With jokes and riddles that appeal to all ages.  
And lots of the items bring more fun and joy –  
They're the same ones sent in when your father was a boy!

This 'zine costs less than 'most any other,  
And its contents will please each father and mother,  
It's better than comics -- each issue's a jewel --  
And it's easy to order at charter renewal.

Is this a good deal? You figure it out.  
It's readin' you're needin', both Scouter and Scout.

For the best program help, there's just one rule:  
Subscribe to *Boys' Life*. It's super cool!