



Aviation

Merit Badge Workbook



This workbook can help you but you still need to read the merit badge pamphlet.

This Workbook can help you organize your thoughts as you prepare to meet with your merit badge counselor.

You still must satisfy your counselor that you can demonstrate each skill and have learned the information. You should use the work space provided for each requirement to keep track of which requirements have been completed, and to make notes for discussing the item with your counselor, not for providing full and complete answers.

If a requirement says that you must take an action using words such as "discuss", "show", "tell", "explain", "demonstrate", "identify", etc, that is what you must do.

Merit Badge Counselors may not require the use of this or any similar workbooks.

No one may add or subtract from the official requirements found in Scouts BSA Requirements (Pub. 33216).

The requirements were last issued or revised in 2014 • This workbook was updated in April 2019.

Scout's Name: _____

Unit: _____

Counselor's Name: _____

Counselor's Phone No.: _____

<http://www.USScouts.Org> • <http://www.MeritBadge.Org>

Please submit errors, omissions, comments or suggestions about this workbook to: Workbooks@USScouts.Org
Comments or suggestions for changes to the requirements for the merit badge should be sent to: Merit.Badge@Scouting.Org

1. Do the following:

a. Define "aircraft."

Describe some kinds and uses of aircraft today.

Kind:

Uses:

Workbook © Copyright 2019 - U.S. Scouting Service Project, Inc. - All Rights Reserved
Requirements © Copyright, Boy Scouts of America (Used with permission.)

This workbook may be reproduced and used locally by Scouts and Scouters for purposes consistent with the programs of the Boy Scouts of America (BSA), the World Organization of the Scout Movement (WOSM) or other Scouting and Guiding Organizations. However it may NOT be used or reproduced for electronic redistribution or for commercial or other non-Scouting purposes without the express permission of the U. S. Scouting Service Project, Inc. (USSSP).

Explain the operation of piston, turboprop, and jet engines.

Piston:

Turboprop:

Jet:

b. Point out on a model airplane the forces that act on an airplane in flight.

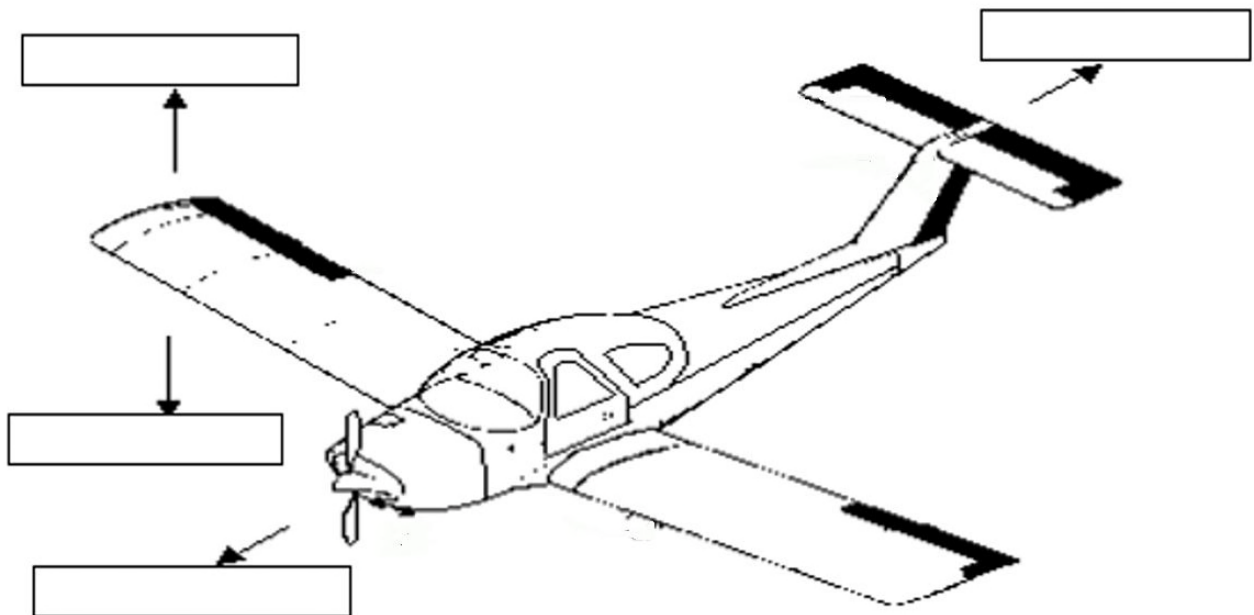

c. Explain how an airfoil generates lift, how the primary control surfaces (ailerons, elevators, and rudder) affect the airplane's attitude, and how a propeller produces thrust.

- c. Explain how an airfoil generates lift, how the primary control surfaces (ailerons, elevators, and rudder) affect the airplane's attitude, and how a propeller produces thrust.

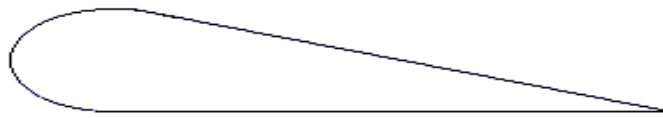

Airfoil:

Ailerons:

Elevators:

Rudder:

Propeller:

- d. Demonstrate how the control surfaces of an airplane are used for takeoff, straight climb, level turn, climbing turn, descending turn, straight descent, and landing.

	Ailerons	Elevators	Rudder	Flaps
Takeoff				
Straight climb				
Level turn				
Climbing turn				
Descending turn				
Straight descent				
Landing				

- e. Explain the following: the sport pilot, the recreational pilot and the private pilot certificates; the instrument rating.

Sport pilot certificate:	
Recreational pilot certificate:	
Private pilot certificate:	

Instrument rating:

2. Do TWO of the following:

- a. Take a flight in an aircraft with your parent's permission. Record the date, place, type of aircraft, and duration of flight, and report on your impressions of the flight.

Date:

Place:

Type of aircraft:

Duration of flight:

Impressions:

- b. Under supervision, perform a preflight inspection of a light airplane.
- c. Obtain and learn how to read an aeronautical chart.
 - Measure a true course on the chart.
 - Correct it for magnetic variation, compass deviation, and wind drift to determine a compass heading.
- d. Using one of many flight simulator software packages available for computers, "fly" the course and heading you established in requirement 2c or another course you have plotted.
- e. Explain the purposes and functions of the various instruments found in a typical single-engine aircraft: attitude indicator, heading indicator, altimeter, airspeed indicator, turn and bank indicator, vertical speed indicator, compass, navigation (GPS and VOR) communication radios, tachometer, oil pressure gauge, and oil temperature gauge.

Attitude indicator:

Heading indicator:

Altimeter:

Airspeed indicator:

Turn and bank indicator:

Vertical speed indicator:

Compass:

Navigation (GPS and VOR):

Communication radios:

Tachometer:

Oil pressure gauge:

Oil temperature gauge:

- c f. Create an original poster of an aircraft instrument panel. Include and identify the instruments and radios discussed in requirement 2e.

3. Do ONE of the following:

- c a. Build and fly a fuel-driven or battery powered electric model airplane. Describe safety rules for building and flying model airplanes.

Tell safety rules for use of glue, paint, dope, plastics, fuel, and battery pack.

- c b. Build a model FPG-9. Get others in your troop or patrol to make their own model, then organize a competition to test the precision of flight and landing of the models.

4. Do ONE of the following:

- c a. Visit an airport. After the visit, report on how the facilities are used, how runways are numbered, and how runways are determined to be "active."

How the facilities are used

How runways are numbered,

How runways are determined to be "active."

- c b. Visit a Federal Aviation Administration facility - a control tower, terminal radar control facility, air route traffic control center, or Flight Standards District Office. (Phone directory listings are under U.S. Government Offices, Transportation Department, and Federal Aviation Administration. Call in advance.)

Report on the operation and your impressions of the facility.

- c c. Visit an aviation museum or attend an air show.

Report on your impressions of the museum or show.

5. Find out about three career opportunities in aviation.

1.	
2.	
3.	

Pick one and find out the education, training, and experience required for this profession. _____

Education:	
Training:	
Experience:	

Discuss this with your counselor, and explain why this profession might interest you.

When working on merit badges, Scouts and Scouters should be aware of some vital information in the current edition of the *Guide to Advancement* (BSA publication 33088). Important excerpts from that publication can be downloaded from <http://usscouts.org/advance/docs/GTA-Excerpts-meritbadges.pdf>. You can download a complete copy of the *Guide to Advancement* from <http://www.scouting.org/filestore/pdf/33088.pdf>.